

Cylinder pressure regulator FM53

spectron lab

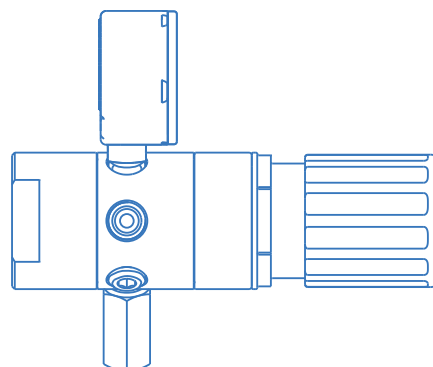

Cylinder pressure regulator FM53



Product features

- 2-stage diaphragm cylinder pressure regulator with extremely stable outlet pressure and anti-vibration device
- For non-corrosive gases and gas mixtures up to quality 6.0
- 6 ports for flexible and individual configuration
- New laboratory-style design
- Central filter
- Suitable for ECD-applications
- Pressure regulator can be evacuated
- Suitable for inlet pressures up to 300 bar
- Max. outlet pressures 1.5 up to 20 bar
- Light weight
- Compact design
- Approved for use with oxygen
- Simple outlet pressure limitation by handwheel
- Easy to install

Technical data

Type	double-stage
Inlet pressure P_1	max. 300 bar
Outlet pressure P_2	1.5 / 4 / 10 / 20 bar
Materials	
Body regulator, relief valve:	chrome plated brass
Valve seat:	PA
Diaphragm:	Hastelloy C276
Soft goods:	EPDM
Filter:	Sintered bronze
In- and outlets	1/4" NPT-F
Temperature range	-30°C to +60°C
Leak rate (to atmosphere)	1×10^{-8} mbar l/s He
(via seat)	1×10^{-6} mbar l/s He
Pressure gauge	Safety pressure gauges ISO5171/K1.6/NG50
Weight	1.7 kg

Flow curves FM53

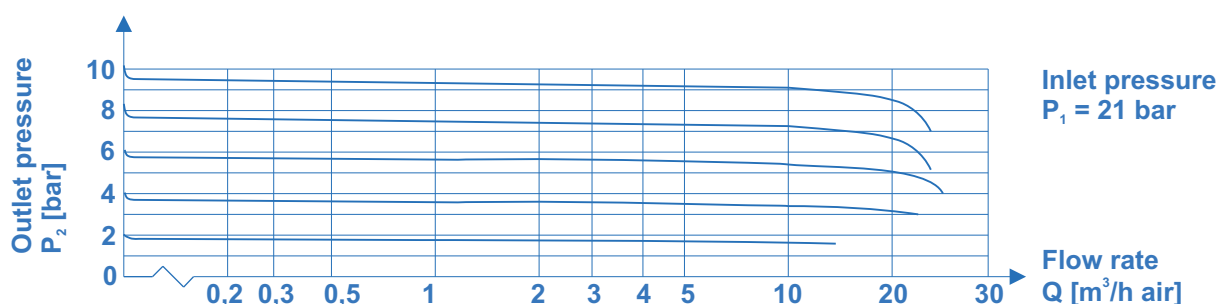

Cylinder pressure regulator FM53

spectro lab

Dimensions

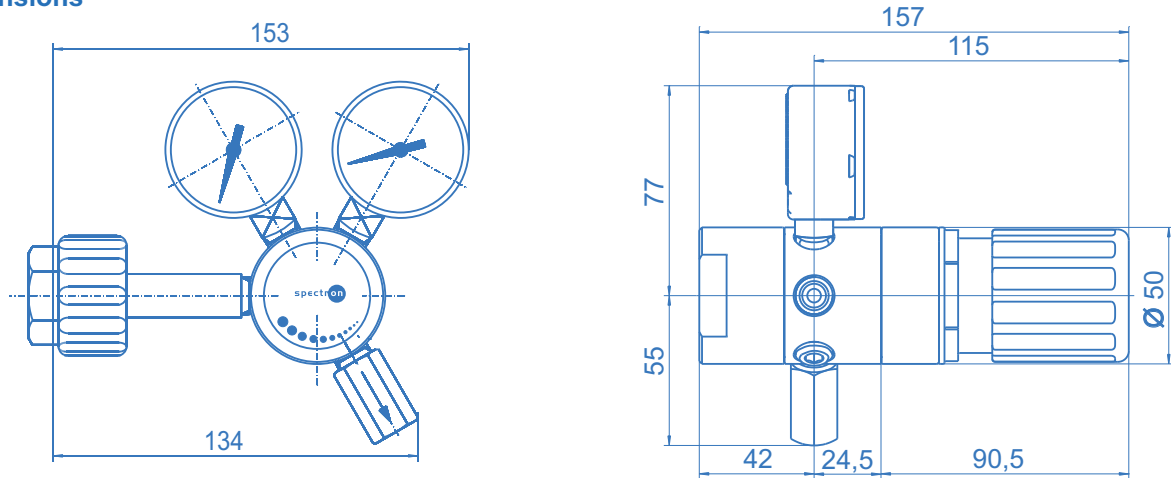

Ordering information:

Cylinder pressure regulator FM53

In- / outlets

- CM 1/4 - 1/8" / 1/4" / 1/2" - OD compression fitting (brass)
- CM 6 - 3 / 6 / 8 / 10 / 12 mm compression fitting (brass)
- CE 1/4 - 1/8" / 1/4" / 1/2" - OD compression fitting (stainless steel)
- CE 6 - 3 / 6 / 8 / 10 / 12 mm compression fitting (stainless steel)
- B - plug
- A - relief valve - 1/4" NPT-F
- xxxx - detailed specification of cylinder connection including the relevant standard and number (e.g. BS no.3 for nitrogen up to 230 bar)
- K - contact gauge
- M - pressure gauge
- 0 - 1/4" NPT-F (port only)

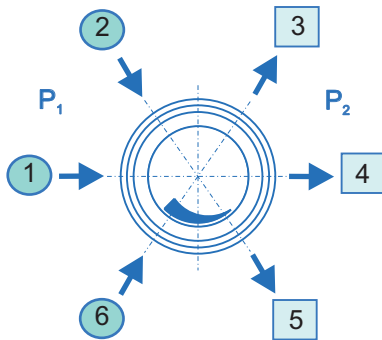

Inlet left: **L**

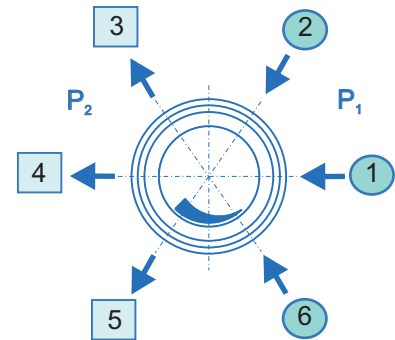

Inlet right: **R**

FM53 - **L** - **300** - **20** - **1** - **2** - **3** - **4** - **5** - **6** - **N2**

Inlet

- L** - left
- R** - right

Inlet pressure P₁

- 100** - max. 100 bar
- 200** - max. 200 bar
- 300** - max. 300 bar

Outlet pressure P₂

- 1,5** - to 1.5 bar
- 4** - to 4 bar
- 10** - to 10 bar
- 20** - to 20 bar

Type of gas

Please specify type of gas (for selection of valve seat materials)

For inlet pressure up to 50 bar and outlet pressure of max. 1,5 or 4 bar please use M51