

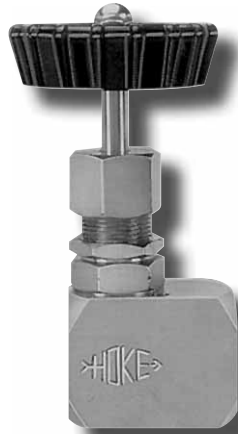

Needle Valves

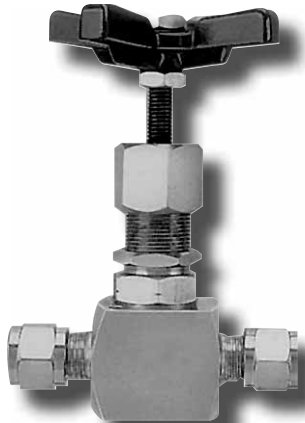

NEW!

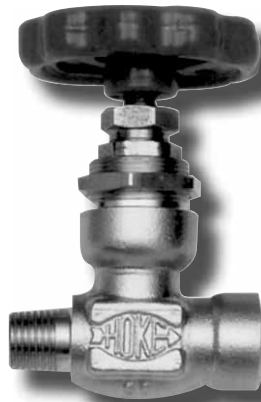

Index

At a Glance	1
1700 Series	5
Forged Body, Integral Bonnet Needle Valves	
2100 Series	8
Bar Stock, Screwed Bonnet Needle Valves	
2200 Series	12
Bar Stock, Screwed Bonnet Needle Valves	
NEW! 2219 Series	16
High Temperature / High Pressure Needle Valves	
2700 Series	20
Bar Stock, Screwed Bonnet Needle Valves	
for Sour Gas Service	
2800 Series	23
Forged Body, Union Bonnet Needle Valves	
3700, 3800, 3900 Series	26
Forged Body, Integral Bonnet Needle Valves	

needle valves



Needle Valves at a Glance

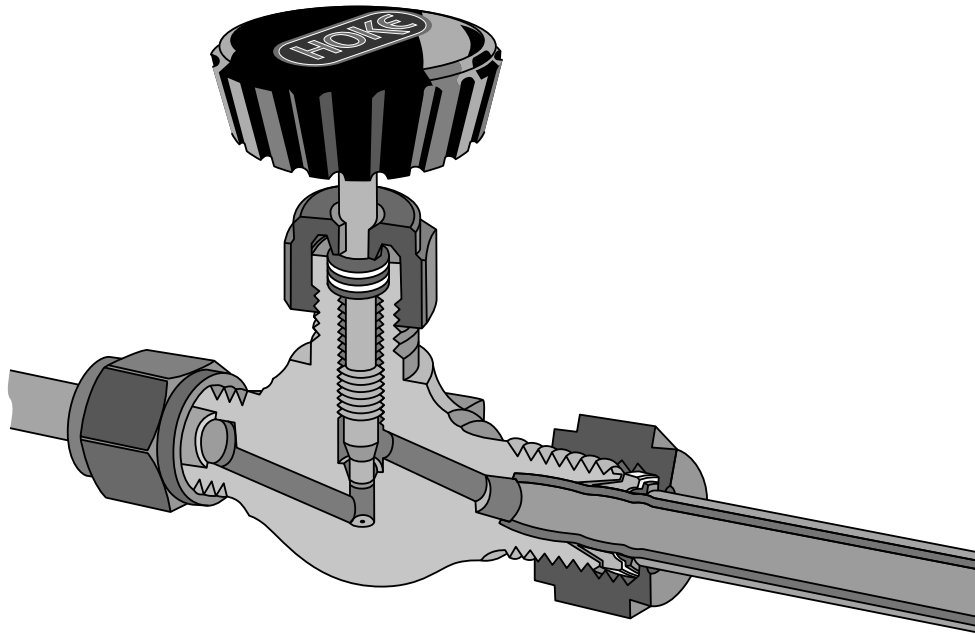

HOKE manufactures a complete line of precision needle valves. Before making your valve selection, be sure to consider the system pressure, operating temperature, required flow and materials of construction. If your application requires a valve not available in this catalog, please contact your HOKE stocking distributor or call HOKE at (864) 574-7966.

In addition to the needle valves in this catalog, HOKE manufactures other lines of specialty needle valves:







- Cylinder valves provide safe flow control for filling and draining cylinders. Valves are available with burst disks, spring relief devices, and metal or PCTFE stem tips. For more information, refer to HOKE's Sampling Cylinders and Accessories catalog (PN 79008).
- Gauge valves are typically used for calibration, isolation, and bleeding of gauges and other instruments. They allow for safe installation and removal of instruments and provide multiple mounting positions. For more information, refer to HOKE's Fluid Control Component catalog (PN 79020).
- Plug valves are used in applications where instant on/off service is necessary. Hoke plug valves are available in quarter-turn (7300 series) or rising stem (7400 series) models. Both designs include a straight through bore, which provides maximum flow and rodability. For more information, refer to the 7300 series catalog (PN 79039) and the 7400 series Catalog (PN 78165).

needle valves

HOKE Incorporated

405 Centura Court • PO Box 4866 • Spartanburg, SC 29303
Phone (864) 574-7966 Fax (864) 587-5608
www.hoke.com • sales@hoke.com

Needle Valves at a Glance

	SERIES	DESCRIPTION/APPLICATIONS	FEATURES	STANDARD BODY MATERIAL
	1700 Series (pg. 5)	<ul style="list-style-type: none"> Panel board instrumentation Pressure gauge valves Sampling systems Research laboratories Oxygen service Corrosive or high pressure service Cylinder Valves 	<ul style="list-style-type: none"> Dyna-Pak® packing Long cycle life Broad selection of fitting connections 	316 stainless steel Monel®
	2100 Series (pg. 8)	<ul style="list-style-type: none"> Hydraulic systems High temperature service Gas sampling Test stands 	<ul style="list-style-type: none"> Choice of Dyna-Pak® or Graph-Lock® high temperature packing High pressure capability Choice of all metal stem or metal stem with PCTFE stem tip 	Brass 316 stainless steel Carbon steel
	2200 Series (pg. 12)	<ul style="list-style-type: none"> Corrosive handling Sampling systems Metering service 	<ul style="list-style-type: none"> Long service life Extended temperature range Dyna-Pak® packing 	316 stainless steel
	NEW! 2219 Series (pg. 16)	<ul style="list-style-type: none"> Severe service applications Steam service in power plants Hot condensates 	<ul style="list-style-type: none"> Meets ANSI 900# specifications High pressure/high temperature design Bubble-tight leak testing at both seat and packing 	316 stainless steel
	2700 Series (pg. 20)	<ul style="list-style-type: none"> Sour gas service Refineries Chemical processing Oil and gas drilling 	<ul style="list-style-type: none"> Dyna-Pak® packing Corrosion resistance Extended life cycle 	316 stainless steel
	2800 Series (pg. 23)	<ul style="list-style-type: none"> High temperature service Corrosive handling Reactive and hot condensates 	<ul style="list-style-type: none"> High temperature service Extended life cycle Choice of various connections 	316 stainless steel
	3700, 3800 and 3900 Series (pg. 26)	<ul style="list-style-type: none"> Instrument air lines Sampling Gas chromatography Cylinder valves Test stands 	<ul style="list-style-type: none"> Choice of stem tips Dyna-Pak® packing Broad selection of connection options Optional color-coded handles for fluid identification 	Brass 316 stainless steel Carbon steel Monel®

Needle Valves at a Glance

MAX. OPERATING PRESSURE @70° F (21° C)	OPERATING TEMP. RANGE	C _v FLOW RANGE (VARIES W/ END CONN.)	ORIFICE SIZES	STANDARD END CONNECTIONS
6000 psig (414 Bar)	Metal stem tip: -65° F to +450° F (-54° C to +232° C) PCTFE stem tip: -20° F to +250° F (-29° C to +121° C)	0.31	0.187" (4.8 mm)	¼", ⅜", ½" Gyrolok® ¼" Male NPT ¼" Female NPT 8 mm Gyrolok®
Brass: 3000 psig (207 Bar) Stainless steel: 6000 psig (414 Bar) Carbon steel: 5000 psig (345 Bar)	Dyna-Pak®/metal stem tip: -65° F to +450° F (-54° C to +232° C) Dyna-Pak®/PCTFE stem tip: -20° F to +250° F (-29° C to +121° C) Graph-Lock®/metal stem tip: -60° F to +600° F (-51° C to +316° C)	0.40 to 1.20	0.188" to 0.313" (4.8 mm to 8.0 mm)	¼", ⅜", ½" Gyrolok® ½" Male NPT ¼", ⅜", ½" Female NPT
5000 psig (345 Bar)	-65° F to +450° F (-54° C to +232° C)	0.12 to 1.4	0.086" to 0.313" (2.2 mm to 8.0 mm)	¼", ⅜", ½" Gyrolok® ½" Male NPT ¼", ⅜", ½" Female NPT 10, and 12 mm Gyrolok®
6000 psig (414 bar)	-100 to +1000 (-75 to +538)	0.47, 1.09, 1.20 (Cv factor for 0.437" orifice not available at time of publication)	0.170" (4.3 mm), 0.250" (6.4 mm), 0.312" (7.9 mm) 0.437" (11.1 mm)	¼", ½", ¾" 1" Gyrolok ¼", ½", ¾", 1" Female NPT 3/8", ½", ¾" 1" Tube socket weld 3/8", ½", ¾" 1" NPS socket weld 12 mm, 22 mm, 25 mm Gyrolok
6000 psig (414 Bar)	-65° F to 450° F (-54° C to 232° C)	0.60	0.187" (4.8 mm)	½" Male NPT x ½" Female NPT ½" Female NPT x ½" Female NPT
Grafoil® packing: 2500 psig (172 Bar) Dyna-Pak® packing: 5000 psig (345 Bar)	Grafoil® packing: -100° F to +700° F (-75° C to +370° C) Dyna-Pak® packing: -40° F to +450° F (-40° C to +232° C)	1.10	0.312" (7.9 mm)	¼", ⅜", ½" Gyrolok® ½" Female NPT ½" Socket weld
316 SS, CS & Monel®: 5000 psig (345 Bar) Brass: 3000 psig (207 Bar)	Metal stem tip: -65° F to +450° F (-54° C to +232° C) PCTFE stem tip: -20° F to +250° F (-29° C to +121° C)	0.07 to 1.1	0.06" to 0.312" (1.5 mm to 7.9 mm)	⅛", ¼", ⅜", ½" Gyrolok® ⅛", ¼", ⅜" Male NPT ⅛", ¼", ½" Female NPT 3, 6, 8, 10, and 12 mm Gyrolok®

Needle Valves at a Glance

Dyna-Pak® Stem Packing System

Dyna-Pak® provides superior sealing performance while reducing maintenance costs. Consisting of alternate wafers of TFE and metal spacers, stem leakage is virtually eliminated while the problems associated with TFE cold flow are minimized.

As the packing nut is tightened, metal spacers squeeze the TFE wafers, driving the TFE against the stem. At the stem, forces are concentrated and the TFE wafers provide multiple line seals. In addition to squeezing the TFE wafers, the metal spacers help contain the TFE and drastically reduce its ability to creep.

Dyna-Pak® packing has the ability to:

- Utilize system pressure to increase effectiveness in eliminating leakage
- Provide reduced operating torque
- Help eliminate fugitive emissions
- Reduce the need for frequent packing adjustments
- Operate in temperatures from -65° to +450° F (-54° to +232° C)

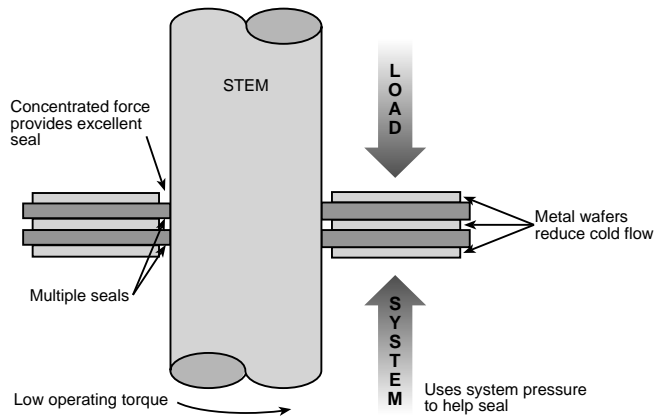

HOKE Needle Valves are Offered With a Choice of Stem Tip Options to Provide Greater Flexibility



Blunt Vee-Point The blunt vee-point stem tip provides full flow with only a few turns of the valve handle



Regulating The regulating stem tip has a gradually tapered tip which allows for greater control of flow.



Non-rotating Metal Stem Tip A non-rotating stem tip is typically used in high cycle applications to extend the service life of the valve. Its purpose is to prevent galling in the seat and on the stem tip. As the valve is closed, the stem tip contacts the valve seat, and is driven straight into it without rotating.



Vee-Point The vee-point stem tip is used to provide leak-tight shutoff in small orifice valves.



PCTFE A PCTFE stem tip requires a lower seating torque than a metal stem tip. It will provide full flow through the valve with only a few handle turns. The PCTFE tip is replaceable and has a maximum temperature of +250° F (+121° C)



Non-rotating PCTFE Stem Tip A non-rotating PCTFE stem tip operates in the same fashion as the non-rotating metal stem tip but requires less seating torque.

Flow capacity of HOKE Needle Valves

The Cv factor is a flow coefficient expressing the rate of flow in gallons per minute of 60° F (16° C) water with a pressure drop of 1 psi across the valve. The flow is dependent on the inlet and outlet pressures, temperature, specific gravity and the Cv coefficient.

To determine the Cv or flow of a **liquid** @ 60° F (16° C):

$$Cv = \frac{GPM}{\sqrt{\frac{\Delta p}{S.G.}}} \quad \text{or} \quad GPM = Cv \sqrt{\frac{\Delta p}{S.G.}}$$

where: $\Delta p = p_1 - p_2$
 p_1 = inlet pressure in psia
 p_2 = outlet pressure in psia
 GPM = flow in gallons per minute
 S.G. = specific gravity of liquid where water = 1 @ 60° F (16° C)

To determine the Cv or flow of a **gas** @ 70° F (21° C):

$$Cv = \frac{SCFH}{1360 \sqrt{\frac{(\Delta p) (p_1)}{(460 + T) (S.G.)}}} \quad \text{or} \quad SCFH = 1360 Cv \sqrt{\frac{(\Delta p) (p_1)}{(460 + T) (S.G.)}}$$

where: $\Delta p = p_1 - p_2$
 p_1 = inlet pressure in psia
 p_2 = outlet pressure in psia
 SCFH = flow in standard cubic feet per hour
 S.G. = specific gravity of gas where air = 1 @ 70° F (21° C) and 14.7 psia
 T = temperature in ° F

Note: Maximum effective Δp for compressible fluids is $\frac{1}{2}p_1$.

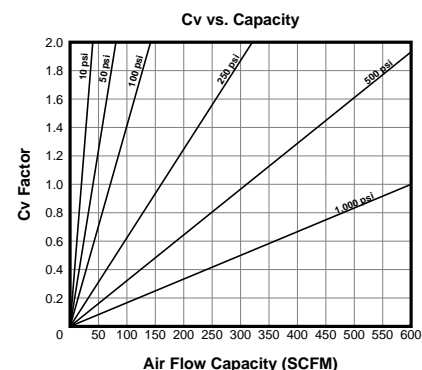
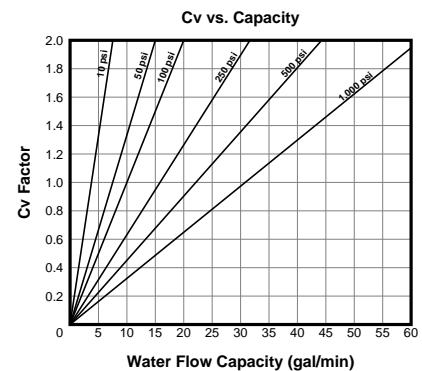



1700 Series

Forged Body, Integral Bonnet Needle Valves

These affordable valves are suited for a wide variety of process control applications. Non-rotating stainless steel or replaceable PCTFE stem tips reduce galling. Dyna-Pak® packing below the stem threads prevents fugitive emissions.



Typical Applications

- Cylinder valves
- Panel board instrumentation
- Pressure gauge valves
- Sampling systems
- Research laboratories
- Oxygen service
- Corrosive or high pressure service

Technical Data

BODY*	316 stainless steel, Monel®
MAXIMUM OPERATING PRESSURE	6000 psig @ 70° F (414 Bar @ 21° C)
OPERATING TEMPERATURE RANGE	<i>Metal stem tip</i> -65° to +450° F (-54° to +232° C) <i>PCTFE stem tip</i> -20° to +250° F (-29° to +121° C)
ORIFICE	0.187" (4.8mm)
Cv FACTOR	0.31

* Consult factory for other materials

Features & Benefits

Safety

- Lock nut secures packing nut to prohibit accidental removal

Long cycle life

- Packing below stem threads prevents fluid from contacting the stem threads
- Non-rotating hardened 17-4PH stainless steel, Monel® or replaceable PCTFE stem tip is combined with a hardened 450 stainless steel - or Monel® thread gland to reduce galling

Helps eliminate fugitive emissions

- Dyna-Pak® packing provides a leak-tight seal with low operating torque

Reliability

- All valves are tested for bubble-tight leakage at both seat and packing

Installation variety

- Broad selection of male NPT, female NPT, and HOKE Gyrolok® fractional or metric tube fitting connections

Panel mounting

- Panel mounting is standard on all models
- Special High Tolerance NPT Thread

needle valves

HOKE Incorporated

405 Centura Court • PO Box 4866 • Spartanburg, SC 29303
Phone (864) 574-7966 Fax (864) 587-5608
www.hoke.com • sales@hoke.com

1700 Series

Materials of Construction

DESCRIPTION	316 STAINLESS STEEL	MONEL®
1 Body	316 stainless steel	Monel®
2 Stem	316 stainless steel	Monel®
<i>Stem tip</i>		
3 Soft	PCTFE	PCTFE
3 Hard	17-4PH stainless steel	Monel®
4 Stem packing	TFE/316 stainless steel wafers	TFE/Monel® wafers
5 Thread gland	450 stainless steel	Monel®
6 Lock nut	316 stainless steel	316 stainless steel
<i>Handle</i>		
7 1711 Series	Aluminum	Aluminum
7 1751 Series	ABS	ABS
8 Panel mounting nut	Nickel-plated brass	Nickel-plated brass

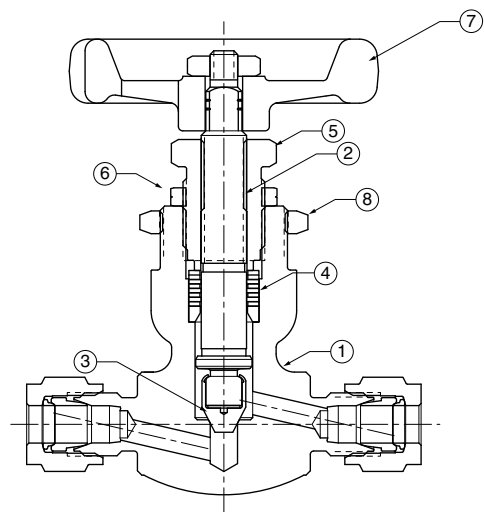

Dimensions

1700 Series: Globe Pattern

INLET A	OUTLET B		D	E	F	H	H'
¼" Gyrolok®	¼" Gyrolok®	inch	3	2½	2½	½	1½
		mm	76	52	54	13	27
¼" male NPT	¼" male NPT	inch	3	2¾	2½	½	1½
		mm	76	56	54	13	27
¼" male NPT	¼" female NPT	inch	3	2½	2½	½	1½
		mm	76	54	54	13	27
¼" female NPT	¼" female NPT	inch	3	2½	2½	½	1½
		mm	76	52	54	13	27
⅜" Gyrolok®	⅜" Gyrolok®	inch	3	2½	2½	½	1½
		mm	76	54	54	13	27
8mm Gyrolok®	8mm Gyrolok®	inch	3	2½	2½	½	1½
		mm	76	68	54	13	27

Dimensions for reference only, subject to change.

Panel mounting dimensions

Panel hole = 5/16" (22.6 mm) diameter

Panel thickness = ¼" (6.4 mm) maximum

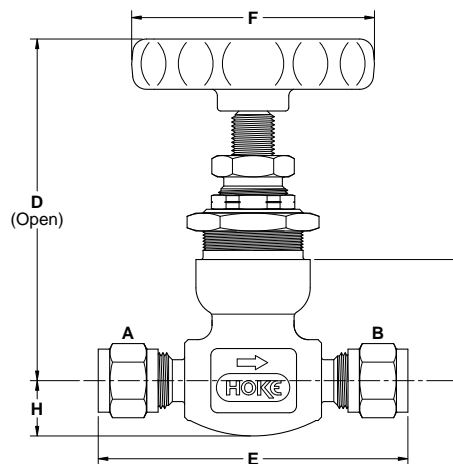

Pressure vs. Temperature Curve

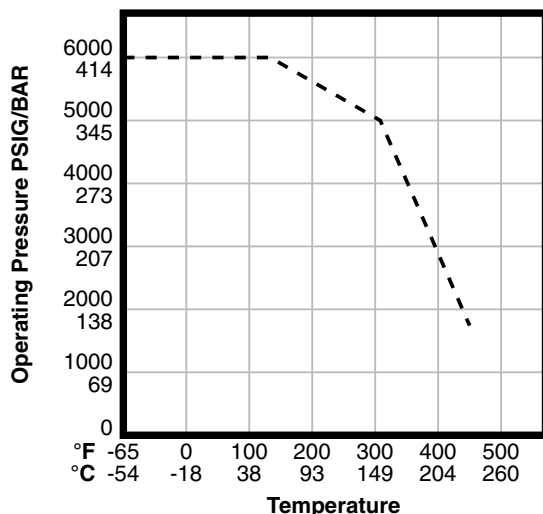

1700 Series

Flow Curves

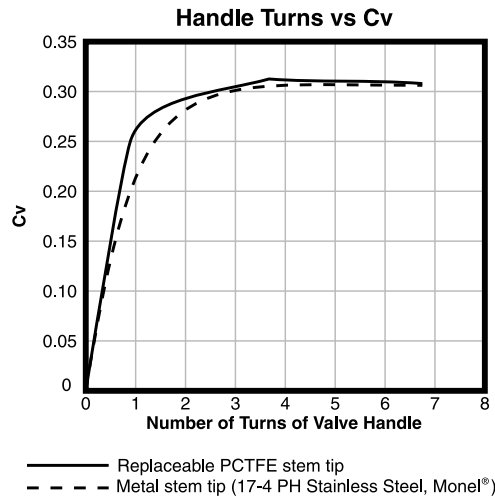

How to Order: Standard Valves



1711L4Y: Globe pattern

1700 Series: Globe Pattern

Metal stem tip for service to +450° F (+232° C)

0.187" (4.7mm) orifice/0.31 Cv

END CONNECTIONS		ORDER BY PART NUMBER	
INLET	OUTLET	316 STAINLESS STEEL	MONEL®
¼" Gyrolok®	¼" Gyrolok®	1711G4Y	—
¼" male NPT	¼" male NPT	1711M4Y	1711M4M
¼" male NPT	¼" female NPT	1711L4Y	—
¼" female NPT	¼" female NPT	1711F4Y	1711F4M
⅜" Gyrolok®	⅜" Gyrolok®	1711G6Y	—
8mm Gyrolok®	8mm Gyrolok®	1711G8YMM	—

NOTE: For applications requiring TPED/PED certification, add a CE suffix to part number. Example: 1711 G4Y-CE.



1751G4Y: Globe pattern

1700 Series: Globe Pattern

PCTFE stem tip for service to +250° F (+121° C)

0.187" (4.7mm) orifice/0.31 Cv

END CONNECTIONS		ORDER BY PART NUMBER	
INLET	OUTLET	316 STAINLESS STEEL	MONEL®
¼" Gyrolok®	¼" Gyrolok®	1751G4Y	—
¼" male NPT	¼" male NPT	1751M4Y	1751M4M
¼" male NPT	¼" female NPT	1751L4Y	—
¼" female NPT	¼" female NPT	1751F4Y	1751F4M
⅜" Gyrolok®	⅜" Gyrolok®	1751G6Y	—
8mm Gyrolok®	8mm Gyrolok®	1751G8YMM	—

FOR YOUR SAFETY

IT IS SOLELY THE RESPONSIBILITY OF THE SYSTEM DESIGNER AND USER TO SELECT PRODUCTS SUITABLE FOR THEIR SPECIFIC APPLICATION REQUIREMENTS AND TO ENSURE PROPER INSTALLATION, OPERATION AND MAINTENANCE OF THESE PRODUCTS. MATERIAL COMPATIBILITY, PRODUCT RATINGS AND APPLICATION DETAILS SHOULD BE CONSIDERED IN THE SELECTION. IMPROPER SELECTION OR USE OF PRODUCTS DESCRIBED HEREIN CAN CAUSE PERSONAL INJURY OR PROPERTY DAMAGE.

Ordering Options

Spare Parts

Spare parts and repair kits are available for all needle valves. Please contact your distributor for specific information.

Cleaning and Testing

When ordering, please specify if oxygen cleaning or helium leak testing is required.

Additional Sizes

Additional sizes and options are available on special request. Please consult your local HOKE distributor.



2100 Series

Bar Stock, Screwed Bonnet Needle Valves

This panel mountable, two-piece design is available in globe and angle patterns for flexibility of installation. Dyna-Pak® packing provides leak-tight sealing with low operating torque. Optional Graph-Lock® packing is available for high-temperature applications. The safety back-seating prevents accidental removal of the stem.



Typical Applications

- Hydraulic systems
- High temperature service to +600° F (+316° C)
- Gas sampling
- Test stands

Technical Data

BODY*	316 stainless steel, carbon steel, brass
MAXIMUM OPERATING PRESSURE	<i>Stainless steel</i> 6000 psig @ 70° F (414 Bar @ 21° C) <i>Carbon steel</i> 5000 psig @ 70° F (345 Bar @ 21° C) <i>Brass</i> 3000 psig @ 70° F (207 Bar @ 21° C)
OPERATING TEMPERATURE RANGE	<i>Dyna-Pak®/Metal stem tip</i> -65° to +450° F (-54° to +232° C) <i>Dyna-Pak®/PCTFE stem tip</i> -20° to +250° F (-29° to +121° C) <i>Graph-Lock®/Metal stem tip</i> -60° to 600° F (-51° to 316° C)
ORIFICE SIZES	0.188" (4.8mm), 0.250" (6.4mm), 0.313" (8.0mm)
Cv FACTORS	0.40 to 1.20

* Consult factory for other materials

Features & Benefits

Safety

- Back seating provides added sealing protection
- Lock pin prevents accidental bonnet disengagement

High pressure capability

- 316 stainless steel valve maximum working pressure is 6000 psig (414 Bar)

Extended temperature range

- Choice of Dyna-Pak® packing or high temperature Graph-Lock® packing

Versatile

- Choice of regulating stem tip or metal stem with nonrotating replaceable PCTFE stem tip, with a variety of end connections

Reliability

- All valves are tested for bubble-tight leakage at both seat and packing

Panel mounting

- Panel mounting is standard on all models
- Special High Tolerance NPT Thread

needle valves

HOKE Incorporated

405 Centura Court • PO Box 4866 • Spartanburg, SC 29303

Phone (864) 574-7966 Fax (864) 587-5608

www.hoke.com • sales@hoke.com

2100 Series

Materials of Construction

DESCRIPTION	BRASS	316 STAINLESS STEEL	CARBON STEEL
1 Body	Brass	316 stainless steel	Carbon steel
2 Stem	316 stainless steel	316 stainless steel	Carbon steel
3 Stem tip soft hard	PCTFE 17-4PH stainless steel	PCTFE 17-4PH stainless steel	PCTFE 17-4PH stainless steel
4 Stem packing Dyna-Pak® packing High temperature packing	TFE/brass wafers —	TFE/316 stainless steel wafers Graph-Lock® TFE wafers	TFE/316 stainless steel wafers Graph-Lock® TFE wafers
5 Bonnet	Brass	316 stainless steel	Carbon steel
6 Handle	ABS wheel, black	ABS wheel, black Aluminum cross, red	ABS wheel, black Aluminum cross, red
7 Valve w/Dyna-Pak® packing Valve w/high temperature packing	Brass	316 stainless steel	Carbon steel
8 Packing nut	Brass	316 stainless steel	Carbon steel
Panel mounting nut	Nickel-plated brass	Nickel-plated brass	Nickel-plated brass

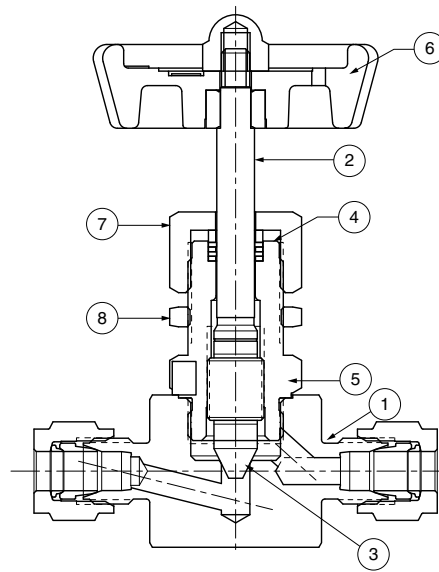

Regulating stem tip shown

Pressure vs. Temperature Curves

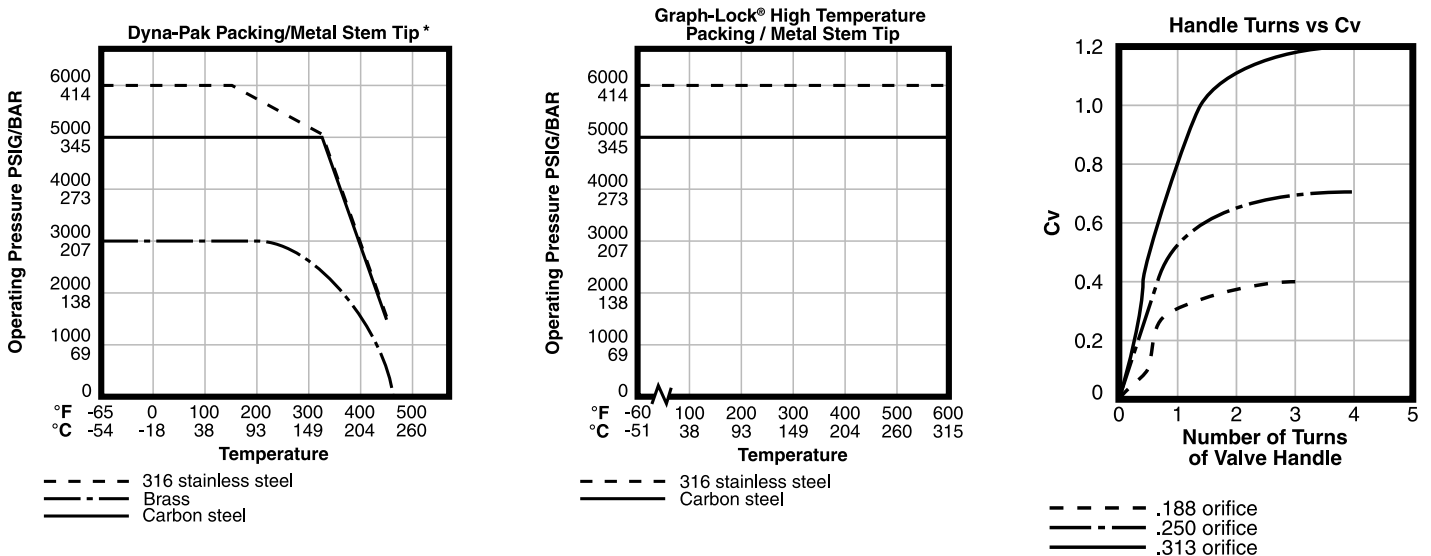

*Curves for PCTFE stem tip are the same as above but limited to -20° to +250°F (-29° to +121 °C)

2100 Series

Dimensions

2100 Series: Globe Pattern

INLET A	OUTLET B		D	E	F			H	H ¹
					HARD SEAT	SOFT SEAT	METAL HANDLE		
¼" Gyrolok®	¼" Gyrolok®	inch	3¼	2½	1½	—	—	½	2½
		mm	83	68	48	—	—	13	20
¼" female NPT	¼" female NPT	inch	3¼	2	1½	1¾	2¾	½	¾
		mm	83	51	48	35	60	13	19
⅜" Gyrolok®	⅜" Gyrolok®	inch	3⅝	2½	1½	1½	—	½	¾
		mm	84	68	48	48	—	13	19
½" Gyrolok®	½" Gyrolok®	inch	3⅝	2¾	1½	—	—	½	¾
		mm	84	75	48	—	—	13	19
½" male NPT	½" female NPT	inch	3¾	2¾	1½	—	—	⅝	3½
		mm	95	70	48	—	—	16	25
½" female NPT	½" female NPT	inch	3¾	2½	2¾	1½	2¾	⅝	1½
		mm	95	64	60	48	60	16	24

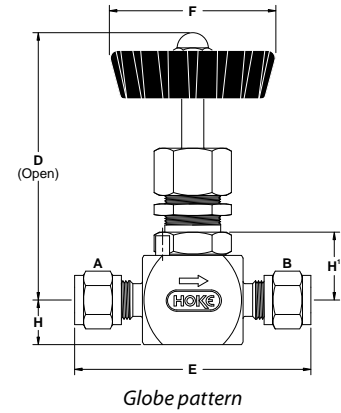

Globe pattern

Dimensions for reference only, subject to change.

* Use metal handle dimensions for high temperature, 2118 Series valves.

2100 Series: Angle Pattern

INLET A	OUTLET B		D	E	F			H	H ¹
					HARD SEAT	SOFT SEAT	METAL HANDLE		
¼" female NPT	¼" female NPT	inch	3⅝	1½	1½	1¾	⅝	1¾	1¾
		mm	84	37	48	35	14	21	21
⅜" female NPT	⅜" female NPT	inch	3¾	1½	1½	—	⅝	¾	¾
		mm	86	38	48	—	16	22	22

Dimensions for reference only, subject to change.

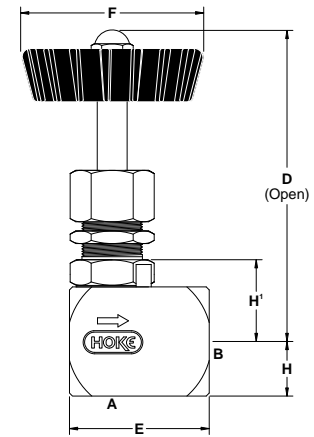

Angle pattern

Panel mounting dimensions

Panel hole for ½" models = 4¾" (19.4 mm) diameter
for all other models = 4¼" (16.2 mm) diameter

Panel thickness = ⅜" (4.7 mm) maximum

How to Order: Standard Valves



2118G4Y: Globe pattern

2100 Series: Globe Pattern

Metal stem tip; Dyna-Pak® packing for service to +450° F (+232° C)

END CONNECTIONS		ORDER BY PART NUMBER			ORIFICE (IN INCHES)	Cv
INLET	OUTLET	BRASS	316 STAINLESS STEEL	CARBON STEEL		
¼" Gyrolok®	¼" Gyrolok®	2112G4B	2112G4Y	—	0.188	0.40
¼" female NPT	¼" female NPT	2112F4B	2112F4Y	2112F4E	0.188	0.40
⅜" Gyrolok®	⅜" Gyrolok®	—	2112G6Y	—	0.250	0.70
⅜" female NPT	⅜" female NPT	2112F6B	2112F6Y	—	0.250	0.70
½" Gyrolok®	½" Gyrolok®	—	2112G8Y	—	0.313	1.20
½" male NPT	½" female NPT	—	2112L8Y	—	0.313	1.20
½" female NPT	½" female NPT	2112F8B	2112F8Y	2112F8E	0.313	1.20

2100 Series: Globe Pattern

Metal stem tip; Graph-Lock® high temperature packing for service to +600° F (+316° C)

END CONNECTIONS		ORDER BY PART NUMBER		ORIFICE (IN INCHES)	Cv
INLET	OUTLET	316 STAINLESS STEEL	CARBON STEEL		
¼" Gyrolok®	¼" Gyrolok®	2118G4Y	—	0.188	0.40
¼" female NPT	¼" female NPT	2118F4Y	2118F4E	0.188	0.40
⅜" female NPT	⅜" female NPT	2118F6Y	—	0.250	0.70
½" female NPT	½" female NPT	2118F8Y	2118F8E	0.313	1.20

FOR YOUR SAFETY

IT IS SOLELY THE RESPONSIBILITY OF THE SYSTEM DESIGNER AND USER TO SELECT PRODUCTS SUITABLE FOR THEIR SPECIFIC APPLICATION REQUIREMENTS AND TO ENSURE PROPER INSTALLATION, OPERATION AND MAINTENANCE OF THESE PRODUCTS. MATERIAL COMPATIBILITY, PRODUCT RATINGS AND APPLICATION DETAILS SHOULD BE CONSIDERED IN THE SELECTION. IMPROPER SELECTION OR USE OF PRODUCTS DESCRIBED HEREIN CAN CAUSE PERSONAL INJURY OR PROPERTY DAMAGE.

2100 Series



2122F4Y: Angle pattern

2100 Series: Globe Pattern

PCTFE stem tip; Dyna-Pak® packing for service to +250° F (+121° C)

END CONNECTIONS		ORDER BY PART NUMBER		ORIFICE (IN INCHES)	Cv
INLET	OUTLET	BRASS	316 STAINLESS STEEL		
¼" female NPT	¼" female NPT	—	2152F4Y	0.188	0.40
½" female NPT	½" female NPT	2152F8B	2152F8Y	0.313	1.20

2100 Series: Angle Pattern

Metal stem tip; Dyna-Pak® packing for service to +450° F (+232° C)

END CONNECTIONS		ORDER BY PART NUMBER		ORIFICE (IN INCHES)	Cv
INLET	OUTLET	BRASS	316 STAINLESS STEEL		
¼" female NPT	¼" female NPT	—	2122F4Y	0.188	0.40
⅜" female NPT	⅜" female NPT	2122F6B	—	0.250	0.70

Ordering Options

Spare Parts

Spare parts and repair kits are available for all needle valves. Please contact your distributor for specific information.

Cleaning and Testing

When ordering, please specify if oxygen cleaning or helium leak testing is required.

Additional Sizes

Additional sizes and options are available upon special request. Please consult your local HOKE distributor.



2200 Series

Bar Stock, Screwed Bonnet Needle Valves

Dyna-Pak® packing below the stem threads, a hardened thread gland and a Hastelloy® C-276 stem tip keep valves leak-tight while providing long cycle life. A choice of two flow capabilities enables use in a variety of severe service applications.



Typical Applications

- Corrosive handling
- Sampling systems
- Metering service

Technical Data

BODY*	316 stainless steel
MAXIMUM OPERATING PRESSURE	5000 psig @ 70° F (345 Bar @ 21° C)
OPERATING TEMPERATURE RANGE	-65° to +450° F (-54° to +232° C)
ORIFICE SIZES	0.086" to 0.313" (2.2 mm to 8.0 mm)
Cv FACTORS	0.12 to 1.40

* Consult factory for other materials

Features & Benefits

Safety

- Lock pin prevents accidental bonnet disengagement

Durability

- Hastelloy® C-276 stem tip provides long service life

Extended temperature range

- Dyna-Pak® packing

Reliability

- All valves are tested for bubble-tight leakage at both seat and packing

Extended cycle life

- Dyna-Pak® packing below stem threads prevents washing away of thread lubricant and contamination of process fluid

Installation variety

- Choose from a broad selection of male NPT, female NPT and HOKE Gyrolok® tube fitting connections in globe or angle patterns

Panel mounting

- Panel mounting is standard on all models
- Special High Tolerance NPT Thread

needle valves

HOKE Incorporated

405 Centura Court • PO Box 4866 • Spartanburg, SC 29303

Phone (864) 574-7966 Fax (864) 587-5608

www.hoke.com • sales@hoke.com

2200 Series

Materials of Construction

DESCRIPTION	MATERIAL
1 Body	316 stainless steel
2 Stem	316 stainless steel
3 Stem tip	Hastelloy® C-276
4 Stem packing	TFE/316 stainless steel wafers
5 Bonnet	316 stainless steel
6 Thread gland	416 stainless steel
<i>Handle</i>	
7 2210, 2220 Series 2230 Series	Aluminum cross, red ABS
8 Panel mounting nut	Nickel-plated brass

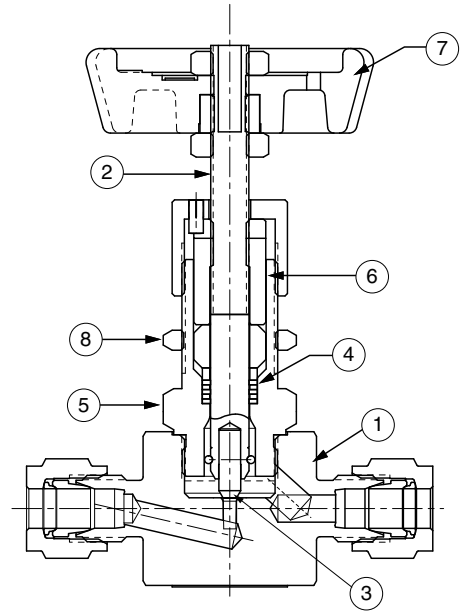

Dimensions

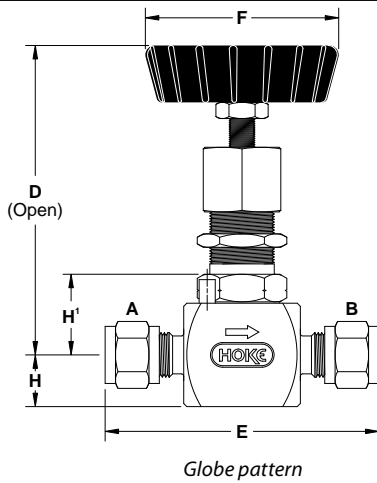

2200 Series: Globe Pattern

INLET A	OUTLET B	D	E	F	H	H'
1/4" Gyrolok®	1/4" Gyrolok®	inch 3 5/16	2 23/32	2 3/8	1/2	2 5/32
		mm 84	67	60	13	20
1/4" female NPT	1/4" female NPT	inch 3 5/16	2	2 3/8	1/2	1 3/16
		mm 84	51	60	13	21
3/8" Gyrolok®	3/8" Gyrolok®	inch 3 1/4	2 1 1/16	2 3/8	1/2	3/4
		mm 83	68	60	13	19
3/8" female NPT	3/8" female NPT	inch 3 5/16	2	2 3/8	1/2	1 3/16
		mm 84	51	60	13	21
1/2" Gyrolok®	1/2" Gyrolok®	inch 3 1/4	2 1 5/16	2 3/8	1/2	2 5/32
		mm 83	75	60	13	20
1/2" male NPT	1/4" female NPT	inch 3 5/16	2 1/8	2 3/8	1/2	1 3/16
		mm 84	54	60	13	21
1/2" female NPT	1/2" female NPT	inch 3 1 1/16	2 1/2	2 3/8	5/8	7/8
		mm 94	64	60	16	22
10mm Gyrolok®	10mm Gyrolok®	inch 3 5/16	2 1 1/16	2 3/8	1/2	2 5/32
		mm 84	68	60	13	20
12mm Gyrolok®	12mm Gyrolok®	inch 3 5/16	2 1 5/16	2 3/8	1/2	3/4
		mm 84	75	60	13	19

Dimensions for reference only, subject to change.

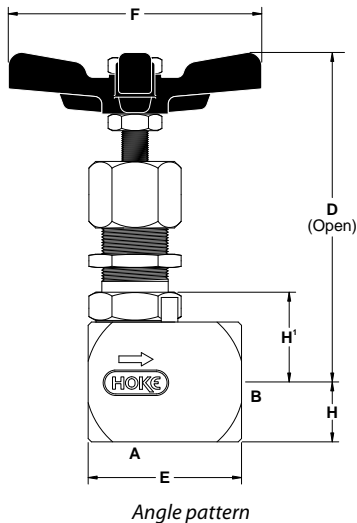

2200 Series: Angle Pattern

INLET A	OUTLET B	D	E	F	H	H'
1/4" female NPT	1/4" female NPT	inch 3 5/16	1 7/16	2 3/8	5/16	7/8
		mm 90	37	60	14	22

Dimensions for reference only, subject to change.

Panel mounting dimensions

Panel hole: for 1/2" models = 4 5/4" (19.4 mm) diameter
for all other models = 4 1/4" (16.2 mm) diameter
Panel thickness = 3/16" (4.7 mm) maximum

2200 Series

Pressure vs. Temperature Curve

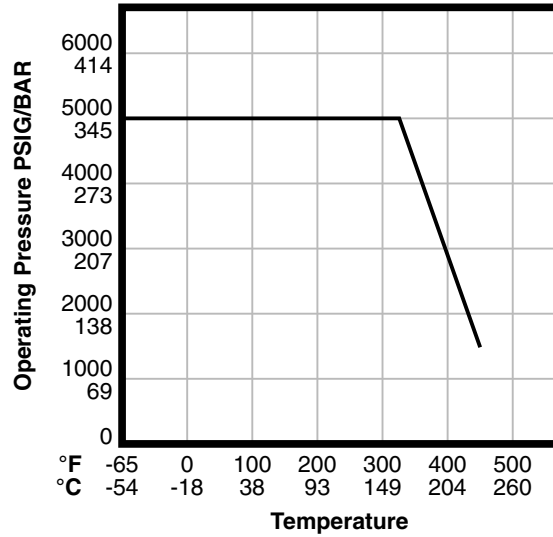

Flow Curves

Handle Turns vs Cv
.086 Orifice

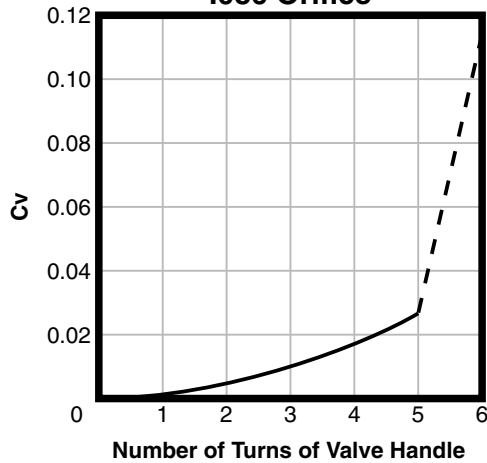

Note: Metering range of valve is within the first 5 handle turns.

Handle Turns vs Cv
.188 Orifice

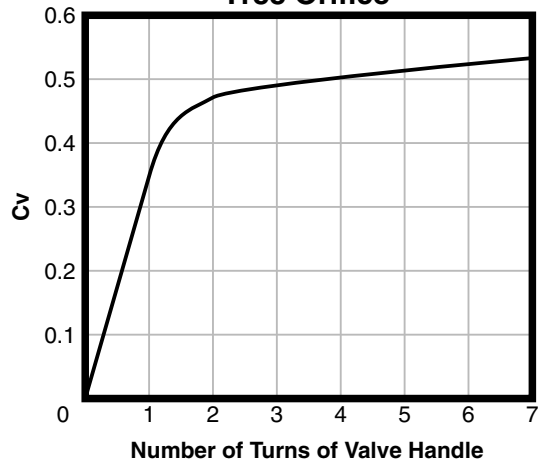

Handle Turns vs Cv
.250 Orifice

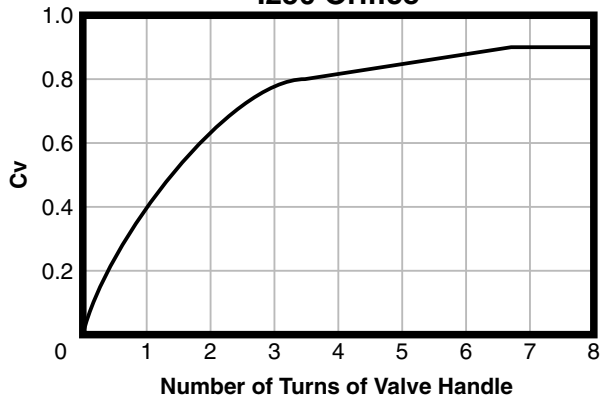

Handle Turns vs Cv
.313 Orifice

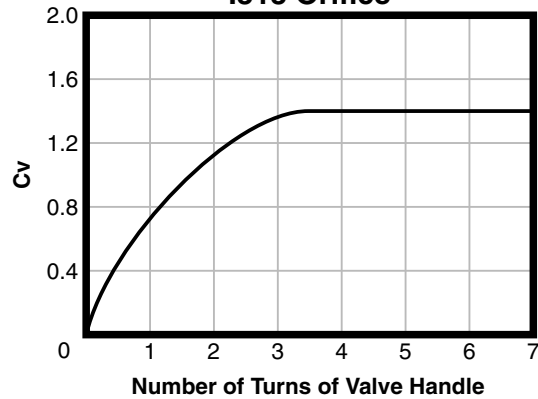

2200 Series

How to Order: Standard Valves

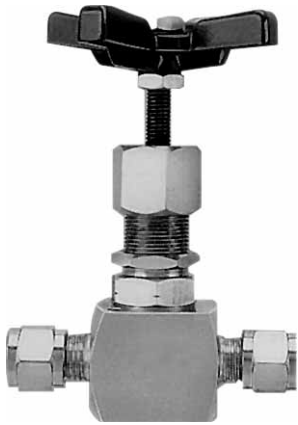

2215G6Y: Globe pattern



Regulating stem tip
(for greater control
of flow)



2225F4Y: Angle pattern



Blunt vee-point tip
(full flow with only
a few handle turns)

2200 Series: Globe Pattern

Blunt vee-point stem tip

END CONNECTIONS		ORDER BY PART NUMBER 316 STAINLESS STEEL	ORIFICE (INCHES)	Cv
INLET	OUTLET			
¼" Gyrolok®	¼" Gyrolok®	2215G4Y	0.188	0.40
¼" female NPT	¼" female NPT	2215F4Y	0.188	0.50
⅜" Gyrolok®	⅜" Gyrolok®	2215G6Y	0.250	0.76
⅜" female NPT	⅜" female NPT	2215F6Y	0.250	0.90
½" Gyrolok®	½" Gyrolok®	2215G8Y	0.250	0.90
½" male NPT	¼" female NPT	2215L84Y	0.188	0.50
½" female NPT	½" female NPT	2215F8Y	0.313	1.40
10mm Gyrolok®	10mm Gyrolok®	2215G10YMM	0.250	0.90
12mm Gyrolok®	12mm Gyrolok®	2215G12YMM	0.250	0.90

2200 Series: Globe Pattern

Regulating stem tip

END CONNECTIONS		ORDER BY PART NUMBER 316 STAINLESS STEEL	ORIFICE (INCHES)	Cv
INLET	OUTLET			
¼" female NPT	¼" female NPT	2232F4Y	0.086	0.12

2200 Series: Angle Pattern

Blunt vee-point stem tip

END CONNECTIONS		ORDER BY PART NUMBER 316 STAINLESS STEEL	ORIFICE (INCHES)	Cv
INLET	OUTLET			
¼" female NPT	¼" female NPT	2225F4Y	0.188	0.55

Ordering Options

Spare Parts

Spare parts and repair kits are available for all needle valves. Please contact your distributor for specific information.

Cleaning and Testing

When ordering, please specify if oxygen cleaning or helium leak testing is required.

Additional Sizes

Additional sizes and options are available on special request. Please consult your local HOKE distributor.

FOR YOUR SAFETY

IT IS SOLELY THE RESPONSIBILITY OF THE SYSTEM DESIGNER AND USER TO SELECT PRODUCTS SUITABLE FOR THEIR SPECIFIC APPLICATION REQUIREMENTS AND TO ENSURE PROPER INSTALLATION, OPERATION AND MAINTENANCE OF THESE PRODUCTS. MATERIAL COMPATIBILITY, PRODUCT RATINGS AND APPLICATION DETAILS SHOULD BE CONSIDERED IN THE SELECTION. IMPROPER SELECTION OR USE OF PRODUCTS DESCRIBED HEREIN CAN CAUSE PERSONAL INJURY OR PROPERTY DAMAGE.



2219 Series

Severe Service Needle Valves

The new Hoke 2219 Needle Valve is an excellent choice for many steam- and severe service applications. Grafoil® packing below the stem threads provides exceptional service at temperatures up to +1000° F (+538° C). The non-rotating 316 stainless steel stem tip prevents galling.



Typical Applications

- Steam service in power plants
- Hot condensates

Technical Data

BODY MATERIAL	316 stainless steel, carbon steel, Hastelloy® C-276, and Monel®
MAXIMUM OPERATING PRESSURE	6000 psig @ 70° F (414 Bar @ 21° C)
PROOF PRESSURE SAFETY FACTOR	2:1
BURST PRESSURE	4:1
TEMPERATURE RANGE	-100° F to + 1000° F @ 1750 psig max. (-75° C to + 538° C @ 120 bar max.)
ORIFICE SIZES	0.170", 0.250", 0.312", and 0.437" (4.3 mm, 6.4 mm, 7.9 mm, and 11.1 mm)
C_v FACTORS*	0.47, 1.09, and 1.20

* C_v factor for 0.437" orifice not available at time of publication

Features & Benefits

- Meets ANSI 900# specifications
- Grafoil® packing below threads isolates threads from media.
- Non-rotating 316 stainless steel stem tip prevents galling
- High pressure / high temperature use
- All standard components are 316 stainless steel
- Standard 316 stainless steel cast handle
- Fractional end connections available up to 1"; metric end connections up to 25 mm
- Gyrolok®, female NPT, NPS-, or tube socket weld end connections
- Bubble-tight leak testing at both seat and packing
- Special High Tolerance NPT Thread

needle valves

HOKE Incorporated

405 Centura Court • PO Box 4866 • Spartanburg, SC 29303
Phone (864) 574-7966 Fax (864) 587-5608
www.hoke.com • sales@hoke.com

2219 Series Severe Service Needle Valve

Dimensions

INLET A	OUTLET B	ORIFICE SIZE	C		D	E	F
			inch	mm			
¼" female NPT	¼" female NPT	0.250" (6.4 mm)	inch	3.4	2.63	2.25	N/A
			mm	86.4	66.8	57.2	N/A
½" female NPT	½" female NPT	0.312" (7.9 mm)	inch	3.4	2.63	2.51	N/A
			mm	86.4	66.8	63.8	N/A
¾" female NPT	¾" female NPT	0.437" (11.1 mm)	inch	3.55	2.63	3.50	N/A
			mm	89.6	66.8	88.9	N/A
1" female NPT	1" female NPT	0.437" (11.1 mm)	inch	3.59	2.63	4.25	N/A
			mm	91.3	66.8	108.0	N/A
¼" Gyrolok®	¼" Gyrolok®	0.170" (4.3 mm)	inch	3.4	2.63	1.87	3.15
			mm	86.4	66.8	47.4	80.1
½" Gyrolok®	½" Gyrolok®	0.250" (6.4 mm)	inch	3.4	2.63	1.50	3.43
			mm	86.4	66.8	38.1	87.1
¾" Gyrolok®	¾" Gyrolok®	0.437" (11.1 mm)	inch	3.53	2.63	2.88	4.87
			mm	89.7	66.8	73.2	123.8
1" Gyrolok®	1" Gyrolok®	0.437" (11.1 mm)	inch	3.53	2.63	2.51	5.00
			mm	89.7	66.8	63.8	120.9
12 mm Gyrolok®	12 mm Gyrolok®	0.250" (6.4 mm)	inch	3.40	2.63	1.51	3.36
			mm	86.4	66.8	38.5	85.4
22 mm Gyrolok®	22 mm Gyrolok®	0.437" (11.1 mm)	inch	3.53	2.63	2.76	4.86
			mm	89.7	66.8	70.1	123.3
25 mm Gyrolok®	25 mm Gyrolok®	0.437" (11.1 mm)	inch	3.53	2.63	2.51	5.11
			mm	89.7	66.8	63.8	129.7
⅜" tube socket weld	⅜" tube socket weld	0.250" (6.4 mm)	inch	3.4	2.63	1.94	2.44
			mm	86.4	66.8	49.3	62.0
½" tube socket weld	½" tube socket weld	0.250" (6.4 mm)	inch	3.40	2.63	1.94	2.44
			mm	86.4	66.8	49.3	62.0
¾" tube socket weld	¾" tube socket weld	0.437" (11.1 mm)	inch	3.53	2.63	2.50	3.50
			mm	89.7	66.8	63.5	88.9
1" tube socket weld	1" tube socket weld	0.437" (11.1 mm)	inch	3.53	2.63	2.50	3.50
			mm	89.7	66.8	63.5	88.9
⅜" NPS socket weld	⅜" NPS socket weld	0.250" (6.4 mm)	inch	3.4	2.63	2.01	2.51
			mm	56.4	66.8	51.05	63.8
½" NPS socket weld	½" NPS socket weld	0.312" (7.9 mm)	inch	3.4	2.63	1.75	2.51
			mm	86.4	66.8	44.45	63.8
¾" NPS socket weld	¾" NPS socket weld	0.437" (11.1 mm)	inch	3.53	2.63	2.50	3.50
			mm	89.7	66.8	63.5	88.9
1" NPS socket weld	1" NPS socket weld	0.437" (11.1 mm)	inch	3.59	2.63	2.50	3.50
			mm	91.3	66.8	63.5	88.9

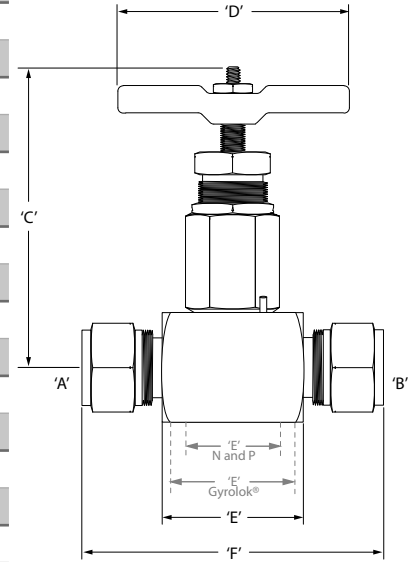

Dimensions for reference only, subject to change.

Materials of Construction*

DESCRIPTION	MATERIAL
1 Handle	316 stainless steel
2 Stem assembly	316 stainless steel
3 Packing nut	316 stainless steel
4 Body	316 stainless steel
5 Packing	Grafoil®
6 Packing washer	316 stainless steel

* This listing contains standard valve information only. See page 19 for a complete list of options.

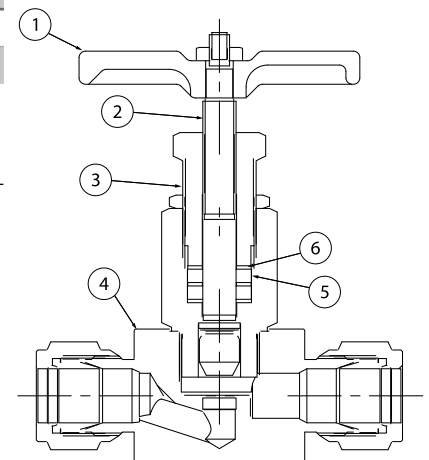

2219 Series Severe Service Needle Valve

Pressure vs. Temperature Curve

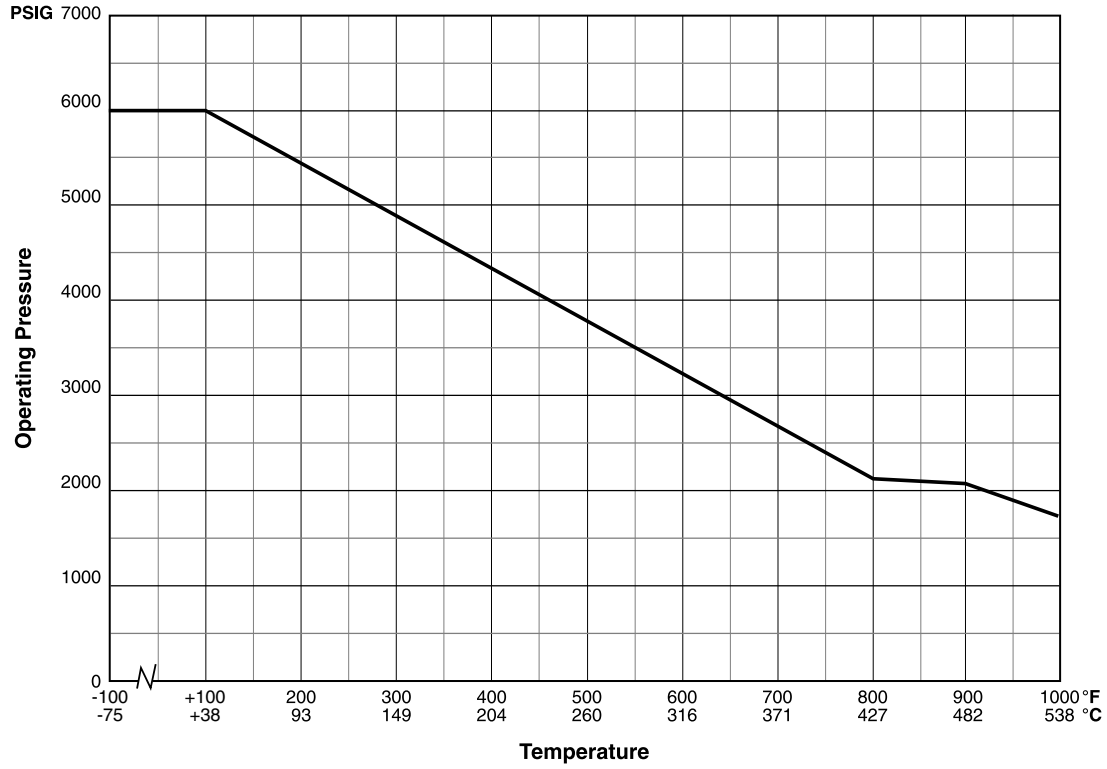

Flow Curves

Handle Turns vs. C_v

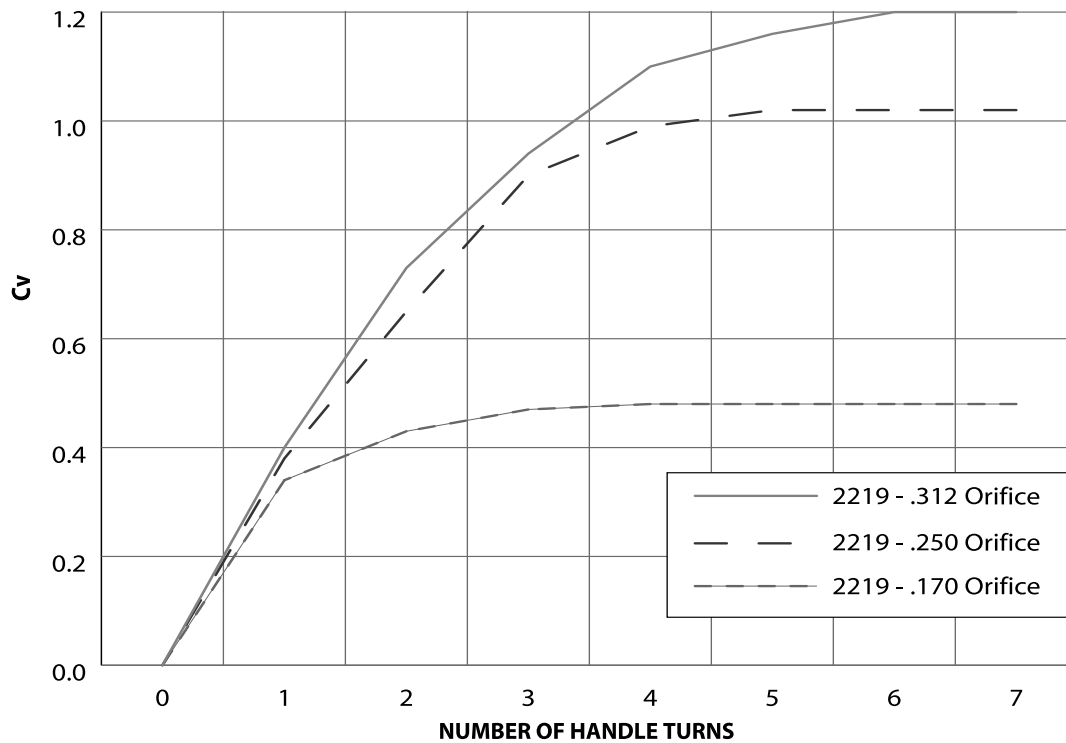

* Data for 0.437" orifice not available at time of publication

2219 Series Severe Service Needle Valve

How to Order: Build-to-Order

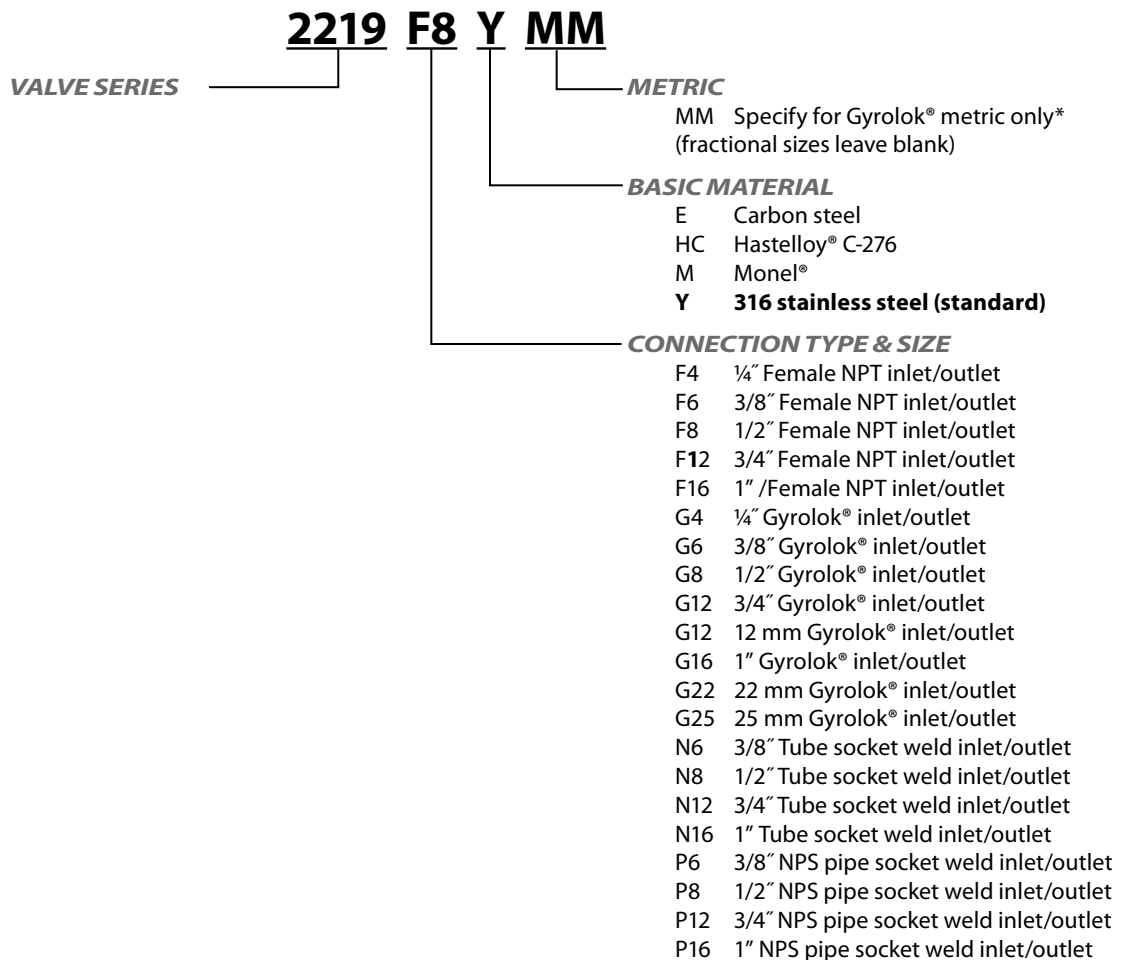

* Consult factory for metric connections and additional material options.

For Your Safety

It is solely the responsibility of the system designer and user to select products suitable for their specific application requirements and to ensure proper installation, operation, and maintenance of these products. Material compatibility, product ratings and application details should be considered in the selection. Improper selection or use of products described herein can cause personal injury or property damage.

Gyrolok® is a registered trademark of HOKE, Inc.

Grafoil® is a registered trademark of Union Carbide Corp.

Hastelloy® is a registered trademark of Haynes International, Inc.

Monel® is a registered trademark of Special Metals Corporation.

www.hoke.com

www.unioncarbide.com

www.haynesintl.com

www.specialmetals.com



2700 Series

Bar Stock, Screwed Bonnet Needle Valves for Sour Gas Service

Featuring packing below the stem threads, nonrotating metal stem tip, hardened thread gland and a 316 stainless steel body, these valves are well suited for sour gas applications as well as other severe service applications.



Typical Applications

- Refineries
- Chemical processing
- Oil and gas exploration

Technical Data

BODY	316 stainless steel
MAXIMUM OPERATING PRESSURE	6000 psig @ 70° F (414 Bar @ 21° C)
OPERATING TEMPERATURE RANGE	-65° to +450° F (-54° to +232° C)
ORIFICE	0.187" (4.8 mm)
Cv FACTOR	0.60
END CONNECTIONS	½" female x ½" female NPT

Features & Benefits

Safety

- Lock pin secures packing nut against accidental removal

Sour gas service

- Materials offer corrosion-resistant properties where hydrogen sulfide is present.

Corrosion resistance

- All wetted parts constructed of high chrome, high nickel austenitic stainless steel provide uniform chemical corrosion properties

Helps eliminate fugitive emissions

- Dyna-Pak® packing below the stem threads prevents fluid from contacting stem threads

Extended cycle life

- Nonrotating 17-4PH stainless steel stem tip and XM-19 stainless steel stem prevent galling

Reliability

- All valves are tested for bubble-tight leakage at both seat and packing
- Special High Tolerance NPT Thread

needle valves

HOKE Incorporated

405 Centura Court • PO Box 4866 • Spartanburg, SC 29303

Phone (864) 574-7966 Fax (864) 587-5608

www.hoke.com • sales@hoke.com

2700 Series

Materials of Construction

DESCRIPTION	MATERIALS
1 Body	316 stainless steel
2 Stem	XM-19 stainless steel
3 Stem tip	17-4PH stainless steel
4 Stem packing	TFE/316 stainless steel wafers
5 Bonnet	XM-19 stainless steel
6 Lock nut	316 stainless steel
7 Handle	Aluminum
8 Packing nut	XM-28 stainless steel

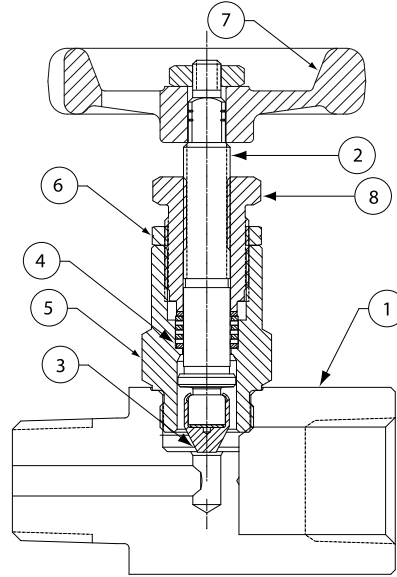

Dimensions

2700 Series: Globe Pattern

INLET A	OUTLET B		D	E	F	H
½" male NPT	½" female NPT	inch	3⅞	2⅞	2⅞	⅝
		mm	78	65	54	16
½" female NPT	½" female NPT	inch	3⅞	2½	2⅞	⅝
		mm	78	64	54	16

Dimensions for reference only, subject to change.

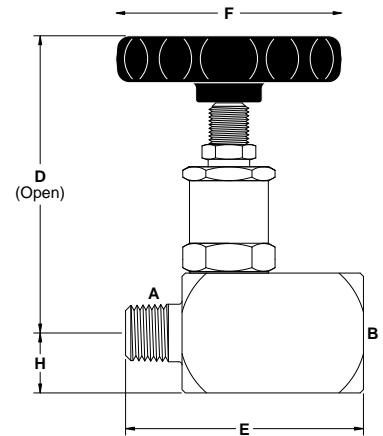

Flow Curve

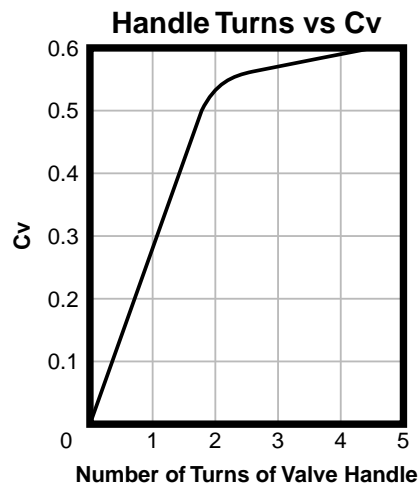

2700 Series

Pressure vs. Temperature Curve

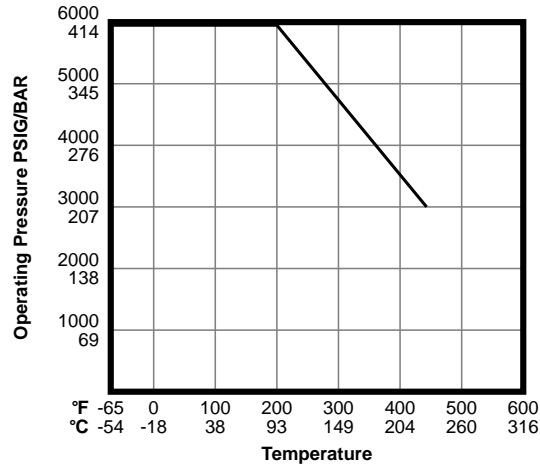

How to Order: Standard Valves

2700 Series: Globe Pattern

17-4PH stainless steel stem tip
0.187" (4.7mm) orifice/0.60 Cv

END CONNECTIONS		ORDER BY PART NUMBER*
INLET	OUTLET	316 STAINLESS STEEL
½" male NPT	½" female NPT	2732L8YX
½" female NPT	½" female NPT	2732F8YX

* It is the end-user's responsibility to determine if this product is compatible with their sour gas application. Contact HOKE for information concerning properties.



2732L8Y: Globe pattern

FOR YOUR SAFETY

IT IS SOLELY THE RESPONSIBILITY OF THE SYSTEM DESIGNER AND USER TO SELECT PRODUCTS SUITABLE FOR THEIR SPECIFIC APPLICATION REQUIREMENTS AND TO ENSURE PROPER INSTALLATION, OPERATION AND MAINTENANCE OF THESE PRODUCTS. MATERIAL COMPATIBILITY, PRODUCT RATINGS AND APPLICATION DETAILS SHOULD BE CONSIDERED IN THE SELECTION. IMPROPER SELECTION OR USE OF PRODUCTS DESCRIBED HEREIN CAN CAUSE PERSONAL INJURY OR PROPERTY DAMAGE.

Ordering Options

Spare Parts

Spare parts and repair kits are available for all needle valves. Please contact your distributor for specific information.

Cleaning and Testing

When ordering, please specify if oxygen cleaning or helium leak testing is required.

Additional Sizes

Additional sizes and options are available on special request. Please consult your local HOKE distributor.



2800 Series

Forged Body, Union Bonnet Needle Valves

For the most severe service applications, these valves feature a stem backseat for safety, a long cycle life with high temperature capability to 700° F (370° C), and a union bonnet for safe, convenient maintenance.



Typical Applications

- High temperature service to 700° F (370° C)
- Corrosive handling
- Reactive and hot condensates

Technical Data

BODY	316 stainless steel
MAXIMUM OPERATING PRESSURE	<i>Grafoil® packing:</i> <ul style="list-style-type: none">• 4000 psig @ 70° F (276 Bar @ 21° C)• 2500 psig @ 700° F (172 Bar @ 370° C) <i>Dyna-Pak® packing:</i> <ul style="list-style-type: none">• 5000 psig @ 70° F (345 Bar @ 21° C)
OPERATING TEMPERATURE RANGE	<i>Grafoil® packing</i> -100° to +700° F (-75° to +370° C) <i>Dyna-Pak® packing</i> -40° to +450° F (-40° to +232° C)
ORIFICE	0.312" (7.9 mm)
Cv FACTOR	1.10

Features & Benefits

Safety

- Integral stem backseat
- Union bonnet design

High temperature service

- Grafoil® packing ring located below stem threads extends service to 700° F (370° C)

Extended cycle life

- 17-4PH stainless steel hardened stem with dry film lubricant on threads and hardened thread gland for increased thread life
- Nonrotating hardened stem tip prevents galling

Reliability

- All valves are tested for bubble-tight leakage at both seat and packing

Installation variety

- Choice of HOKE Gyrolok® tube fittings, female NPT, or tube socket weld connections

Panel mounting

- Panel mounting is standard on all models
- Special High Tolerance NPT Thread

needle valves

HOKE Incorporated

405 Centura Court • PO Box 4866 • Spartanburg, SC 29303

Phone (864) 574-7966 Fax (864) 587-5608

www.hoke.com • sales@hoke.com

2800 Series

Materials of Construction

DESCRIPTION	MATERIAL
1 Body	316 stainless steel
2 Stem	17-4PH stainless steel
3 Stem tip	17-4PH stainless steel
<i>Stem packing</i>	
4 Grafoil® packing	Grafoil®
Dyna-Pak® packing	TFE/316 stainless steel wafer
5 Ring gland	316 stainless steel
6 Thread gland	416 stainless steel
7 Housing	XM-19 stainless steel
8 Adapter nut	316 stainless steel
9 Handle	316 stainless steel
10 Packing nut	316 stainless steel
11 Panel mounting nut	316 stainless steel

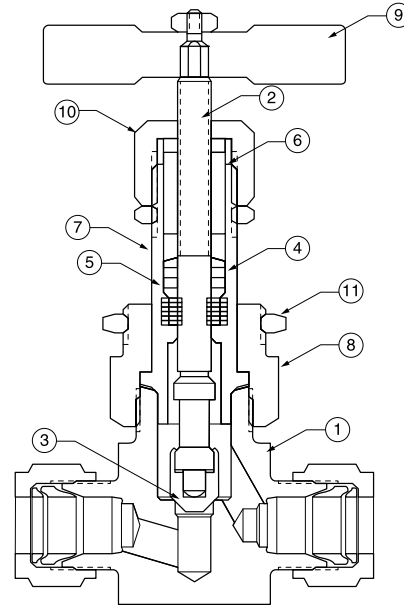

Dimensions

INLET A AND OUTLET B		D	E	F	H	H'
¼" Gyrolok®	inch	4¾	2⅞	2⅞	⅞	1⅜½
	mm	121	75	67	16	36
⅜" Gyrolok®	inch	4¾	2⅞	2⅞	⅞	1⅜½
	mm	121	75	67	16	36
⅜" socket weld	inch	4¾	2⅞	2⅞	⅞	1⅜½
	mm	121	62	67	16	36
½" Gyrolok®	inch	4¾	3⅞	2⅞	⅞	1⅜½
	mm	121	84	67	16	36
½" female NPT	inch	4¾	2⅞	2⅞	⅞	1⅜½
	mm	121	62	67	16	36
½" socket weld	inch	4¾	2⅞	2⅞	⅞	1⅜½
	mm	121	62	67	16	36

Dimensions for reference only, subject to change.

Panel mounting

Panel hole = 1⅜" (30.2 mm) diameter

Panel thickness = ⅜" (4.7 mm) maximum

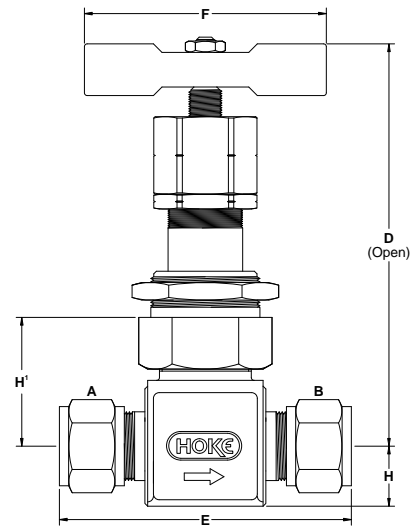

2800 Series

Curves

Handle Turns vs Cv

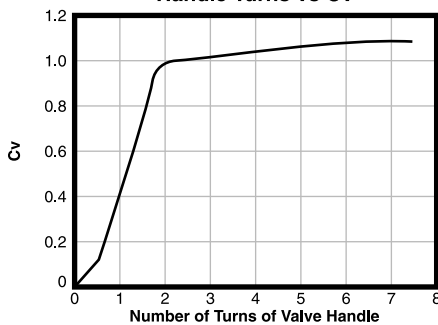

Pressure vs Temperature

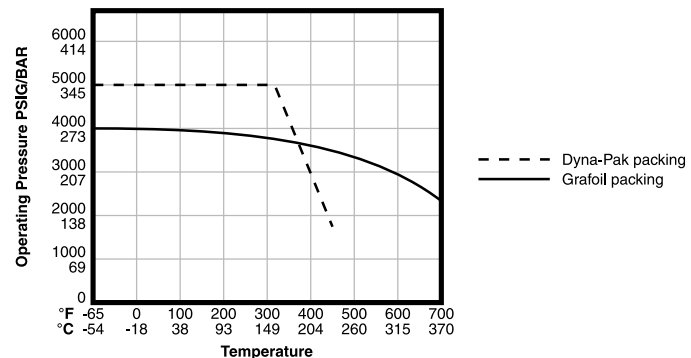

2800 Series

How to Order: Standard Valves



2813F8Y: Globe pattern

2800 Series Globe Pattern

Metal stem tip; Dyna-Pak® packing for service to +450° F (232° C) at 1800 psi

0.312" orifice/1.10 Cv

END CONNECTIONS	ORDER BY PART NUMBER
INLET AND OUTLET	316 STAINLESS STEEL
½" female NPT	2813F8Y
½" Gyrolok®	2813G8Y



2811G8Y: Globe pattern

2800 Series Globe Pattern

Metal stem tip; Grafoil® packing for service to +700° F (371° C) at 2500 psi

0.312" orifice/1.10 Cv

END CONNECTIONS	ORDER BY PART NUMBER
INLET AND OUTLET	316 STAINLESS STEEL
¼" Gyrolok®	2811G4Y
⅜" Gyrolok®	2811G6Y
⅜" socket weld	2811N6Y
½" Gyrolok®	2811G8Y
½" female NPT	2811F8Y
½" socket weld	2811N8Y

FOR YOUR SAFETY

IT IS SOLELY THE RESPONSIBILITY OF THE SYSTEM DESIGNER AND USER TO SELECT PRODUCTS SUITABLE FOR THEIR SPECIFIC APPLICATION REQUIREMENTS AND TO ENSURE PROPER INSTALLATION, OPERATION AND MAINTENANCE OF THESE PRODUCTS. MATERIAL COMPATIBILITY, PRODUCT RATINGS AND APPLICATION DETAILS SHOULD BE CONSIDERED IN THE SELECTION. IMPROPER SELECTION OR USE OF PRODUCTS DESCRIBED HEREIN CAN CAUSE PERSONAL INJURY OR PROPERTY DAMAGE.

Ordering Options

Spare Parts

Spare parts and repair kits are available for all needle valves. Please contact your distributor for specific information.

Cleaning and Testing

When ordering, please specify if oxygen cleaning or helium leak testing is required.

Additional Sizes

Additional sizes and options are available on special request. Please consult your local HOKE distributor.



3700, 3800, 3900 Series

Forged Body, Integral Bonnet Needle Valves

Offered in four different body materials, this group of valves can handle a wide range of general purpose liquid and gas applications. Six types of stem tips are available, including two styles of vee-points.



Typical Applications

- Instrument air lines
- Sampling
- Gas chromatography
- Test stands
- Cylinder valves

Technical Data

BODY*	316 stainless steel, Monel®, carbon steel, brass
MAXIMUM OPERATING PRESSURE	316 stainless steel, Monel®, carbon steel 5000 psig @ 70° F (345 Bar @ 21° C) Brass 3000 psig @ 70° F (207 Bar @ 21° C)
OPERATING TEMPERATURE RANGE	Metal stem tip -65° to +450° F (-54° to +232° C) PCTFE stem tip -20° to +250° F (-29° to +121° C)
ORIFICE SIZES	0.060" to 0.312" (1.5 mm to 7.9 mm)
Cv FACTORS	0.07 to 1.10

* Consult factory for other materials

Features & Benefits

Safety

- Integral bonnet provides differential thread pitch between stem threads and packing nut thread preventing accidental stem removal

Stem tip options

- A choice of PCTFE, metal, vee-point, blunt vee-point, or regulating stem tips

Helps eliminate fugitive emissions

- Dyna-Pak® packing provides a leak-tight seal with low operating torque in deep vacuum or high pressure applications

Dependability

- All valves are tested for bubble-tight leakage at both seat and packing

Installation variety

- Broad selection of male NPT, female NPT, and HOKE Gyrolok® fractional or metric tube fitting connections

Handle options

- Color-coded handles are available for identifying system fluids

Panel mounting available

- All models can be ordered for panel mounting

Easy maintenance

- All models can be panel mounted without packing disruption. Packing can be adjusted without removal from panel
- Special High Tolerance NPT Thread

HOKE Incorporated

405 Centura Court • PO Box 4866 • Spartanburg, SC 29303
Phone (864) 574-7966 Fax (864) 587-5608
www.hoke.com • sales@hoke.com

needle valves

3700, 3800, 3900 Series

Materials of Construction

	DESCRIPTION	BRASS	316 STAINLESS STEEL	CARBON STEEL	MONEL®
1	Body	Brass	316 stainless steel	Carbon steel	Monel®
2	Stem	316 stainless steel	316 stainless steel	316 stainless steel	Monel®
3	Stem tip	PCTFE	PCTFE	PCTFE	PCTFE
	soft	17-4PH stainless steel	17-4PH stainless steel	17-4PH stainless steel	Monel®
4	Stem packing	TFE/brass wafers	TFE/316 stainless steel wafers	TFE/316 stainless steel wafers	TFE/Monel® wafers
5	Handle	ABS	ABS	ABS/aluminum	ABS
6	Panel mounting nut	Nickel-plated brass	Nickel-plated brass	Nickel-plated brass	Nickel-plated brass

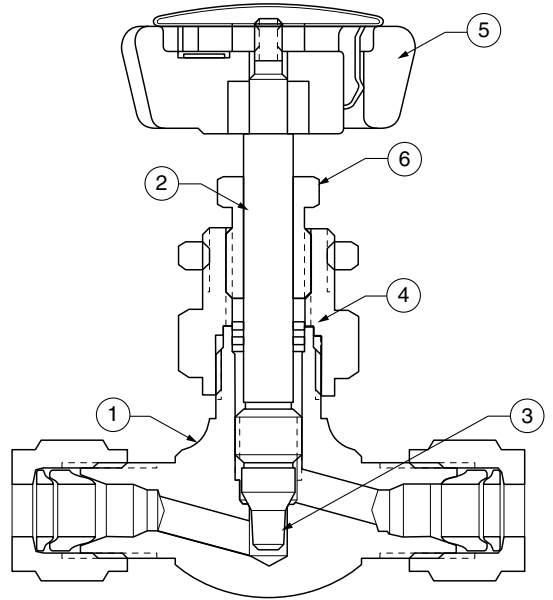

Shown with regulating stem tip

Pressure vs. Temperature Curves

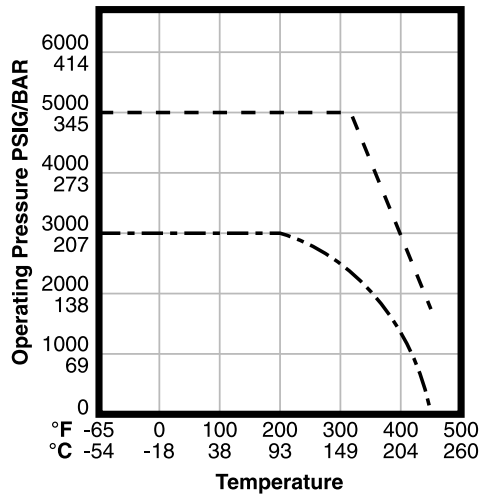

--- 316 stainless steel, carbon steel, Monel®
 - · - Brass

Flow Curves

3700 Series
Handle Turns vs Cv*

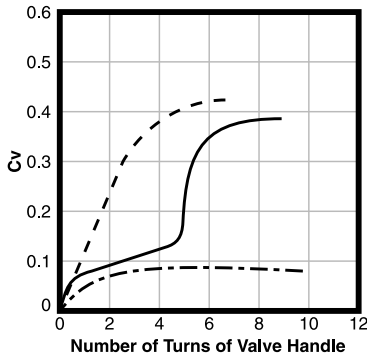

--- PCTFE stem tip
 — Regulating stem tip
 - · - Vee-point tip

* No data currently available for blunt vee-point stem tip

3800 Series
Handle Turns vs Cv

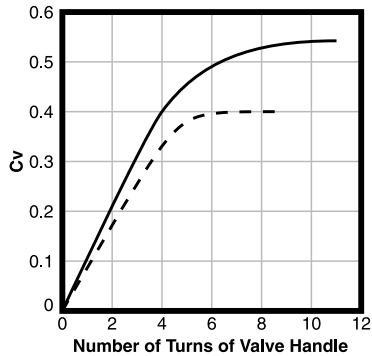

--- PCTFE stem tip
 — Regulating stem tip

3900 Series
Handle Turns vs Cv

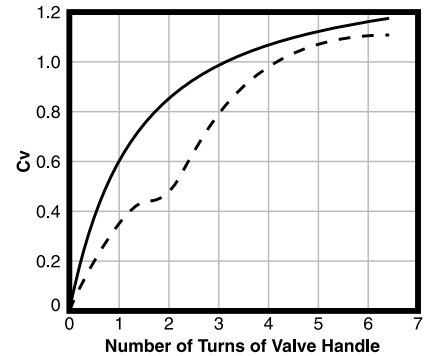

--- PCTFE stem tip
 — Regulating stem tip

3700, 3800, 3900 Series

Dimensions

3700 Series: Globe Pattern

Vee-point stem tip

INLET A	OUTLET B		D	E	F	H
1/8" male NPT	1/8" male NPT	inch	2 3/16	1 3/4	1 1/16	2 5/4
		mm	56	44	37	10
1/4" Gyrolok®	1/4" Gyrolok®	inch	2 3/16	2 3/8	1 1/16	2 5/4
		mm	56	60	37	10
1/4" male NPT	1/4" male NPT	inch	2 3/16	1 3/4	1 1/16	2 5/4
		mm	56	44	37	10

Dimensions for reference only, subject to change.

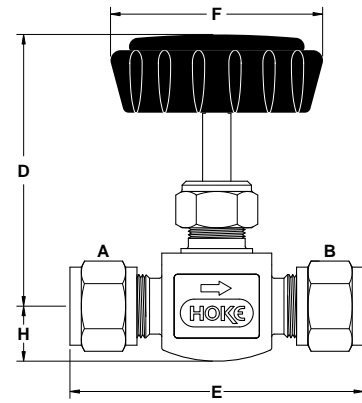

3700/3800 Series globe pattern

3700 Series: Globe Pattern

Regulating and PCTFE stem tips

INLET A	OUTLET B		D	D ^{1,*}	E	F	H	H ^{1,*}
1/8" Gyrolok®	1/8" Gyrolok®	inch	2 7/32	2 3/4	2 1/8	1 1/16	1 3/4	1 1/2
		mm	56	70	54	37	8	26
1/8" male NPT	1/8" male NPT	inch	2 1/8	2 1/2	1 3/4	1 1/16	2 5/4	1 9/16
		mm	54	67	44	37	10	24
1/8" male NPT	1/8" female NPT	inch	2 1/8	2 1/2	1 3/4	1 1/16	2 5/4	1 5/16
		mm	54	67	44	37	10	24
1/8" female NPT	1/8" female NPT	inch	2 1/8	2 1/2	1 3/4	1 1/16	2 5/4	1 5/16
		mm	54	67	44	37	10	24
1/4" Gyrolok®	1/4" Gyrolok®	inch	2 1/8	2 1/2	2 3/8	1 1/16	2 5/4	1 9/16
		mm	54	67	60	37	10	24
1/4" male NPT	1/4" Gyrolok®	inch	2 1/8	2 1/2	2 3/16	1 1/16	2 5/4	1 5/16
		mm	54	67	56	37	10	24
1/4" male NPT	1/4" male NPT	inch	2 1/8	2 1/2	2	1 1/16	2 5/4	1 5/16
		mm	54	67	51	37	10	24
3mm Gyrolok®	3mm Gyrolok®	inch	2 3/16	2 3/4	2 1/8	1 1/16	1 3/4	1 1/2
		mm	56	70	54	37	8	26
6mm Gyrolok®	6mm Gyrolok®	inch	2 1/8	2 1/2	2 3/8	1 1/16	2 5/4	1 5/16
		mm	54	67	60	37	10	24
8mm Gyrolok®	8mm Gyrolok®	inch	2 1/8	2 1/2	2 3/8	1 1/16	2 5/4	1 5/16
		mm	54	67	60	37	10	24

Dimensions for reference only, subject to change.

* D¹ and H¹ for valves with panel mounting.

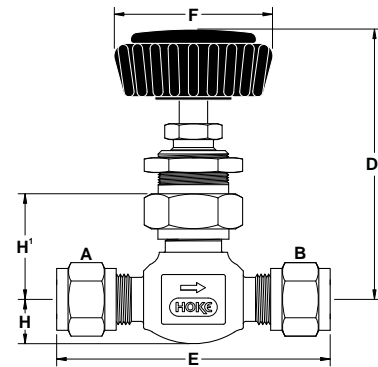

3700/3800 Series globe pattern with D Style panel mounting

3700 Series: Angle Pattern

Regulating and PCTFE Stems

INLET A	OUTLET B		D	D ^{1,*}	E	F	H	H ^{1,*}
1/8" Gyrolok®	1/8" Gyrolok®	inch	2 7/32	2 3/4	1 1/2	1 1/16	1 3/4	1 1/4
		mm	56	70	38	37	26	26
1/8" male NPT	1/8" male NPT	inch	2 1/8	2 1/2	1 1/4	1 1/16	7/8	1 5/16
		mm	54	67	32	37	22	24
1/8" female NPT	1/8" female NPT	inch	2 1/8	2 1/2	1 1/4	1 1/16	7/8	1 5/16
		mm	54	67	32	37	22	24
1/8" male NPT	1/4" Gyrolok®	inch	2 1/8	2 1/2	1 1/2	1 1/16	7/8	1 5/16
		mm	54	67	40	37	22	24
1/4" Gyrolok®	1/4" Gyrolok®	inch	2 1/8	2 1/2	1 1/2	1 1/16	1 3/16	1 5/16
		mm	54	67	40	37	30	24
1/4" male NPT	1/4" Gyrolok®	inch	2 1/8	2 1/2	1 1/2	1 1/16	7/8	1 5/16
		mm	54	67	40	37	22	24
1/4" male NPT	1/4" male NPT	inch	2 1/8	2 1/2	1 1/4	1 1/16	7/8	1 5/16
		mm	54	67	32	37	22	24
6mm Gyrolok®	6mm Gyrolok®	inch	2 1/8	2 1/2	1 3/4	1 1/16	1 3/16	1 5/16
		mm	54	67	40	37	30	24

Dimensions for reference only, subject to change.

* D¹ and H¹ for valves with panel mounting.

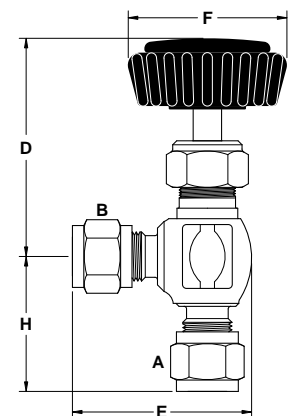

3700/3800 Series angle pattern

3700, 3800, 3900 Series

Dimensions

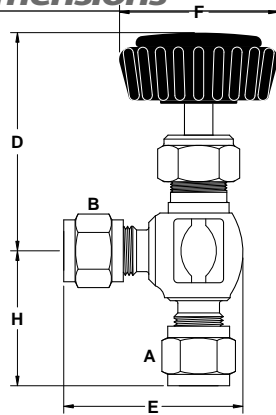

3700/3800 Series angle pattern

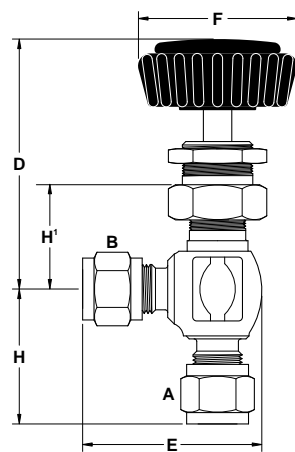

3700/3800 Series angle pattern with P-style panel mounting

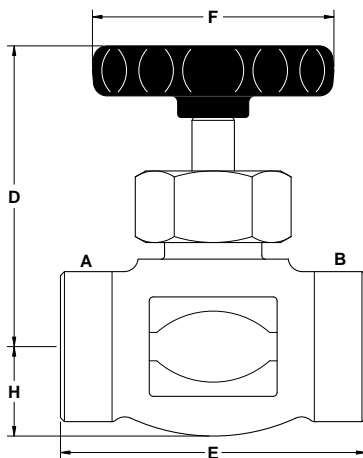

3900 Series globe pattern

3800 Series: Globe Pattern

Regulating and PCTFE stem tips

INLET A	OUTLET B	D	D ^{1*}	E	F		H	H ^{1*}	
					METAL STEM	PCTFE STEM			
¼" male NPT	¼" female NPT	inch	2 ²⁵ / ₃₂	2 ²⁵ / ₃₂	1 ⁷ / ₈	1 ⁷ / ₈	1 ¹ / ₁₆	3 ³ / ₆₄	1 ¹ / ₆₄
		mm	71	71	48	48	37	12	26
¼" female NPT	¼" female NPT	inch	2 ²⁵ / ₃₂	2 ²⁵ / ₃₂	1 ⁷ / ₈	1 ⁷ / ₈	1 ¹ / ₁₆	3 ³ / ₆₄	1 ¹ / ₆₄
		mm	71	71	48	48	37	12	26
¼" male NPT	⅜" Gyrolok®	inch	2 ²⁵ / ₃₂	2 ²⁵ / ₃₂	2 ⁷ / ₃₂	1 ⁷ / ₈	—	3 ³ / ₆₄	1 ¹ / ₆₄
		mm	71	71	56	48	—	12	26
⅜" Gyrolok®	⅜" Gyrolok®	inch	2 ²⁵ / ₃₂	2 ²⁵ / ₃₂	2 ¹ / ₁₆	1 ⁷ / ₈	1 ¹ / ₁₆	3 ³ / ₆₄	1 ¹ / ₆₄
		mm	71	71	65	48	37	12	26
⅜" male NPT	⅜" male NPT	inch	2 ²⁵ / ₃₂	2 ²⁵ / ₃₂	1 ⁷ / ₈	1 ⁷ / ₈	1 ¹ / ₁₆	3 ³ / ₆₄	1 ¹ / ₆₄
		mm	71	71	48	48	37	12	26
½" Gyrolok®	½" Gyrolok®	inch	2 ²⁵ / ₃₂	2 ²⁵ / ₃₂	2 ¹³ / ₁₆	1 ⁷ / ₈	1 ¹ / ₁₆	3 ³ / ₆₄	1 ¹ / ₆₄
		mm	71	71	71	48	37	12	26
10mm Gyrolok®	10mm Gyrolok®	inch	2 ²⁵ / ₃₂	2 ²⁵ / ₃₂	2 ¹ / ₁₆	1 ⁷ / ₈	1 ¹ / ₁₆	3 ³ / ₆₄	1 ¹ / ₆₄
		mm	71	71	65	48	37	12	26
12mm Gyrolok®	12mm Gyrolok®	inch	2 ²⁵ / ₃₂	2 ²⁵ / ₃₂	2 ¹³ / ₁₆	1 ⁷ / ₈	1 ¹ / ₁₆	3 ³ / ₆₄	1 ¹ / ₆₄
		mm	71	71	71	48	37	12	26

Dimensions for reference only, subject to change.

* D¹ and H¹ for valves with panel mounting.

3800 Series: Angle Pattern

Regulating and PCTFE stem tips

INLET A	OUTLET B	D	D ^{1*}	E	F	H	H ^{1*}	
¼" male NPT	¼" female NPT	inch	2 ¹ / ₁₆	2 ¹ / ₁₆	1 ² / ₄	1 ¹ / ₁₆	3 ³ / ₃₂	1
		mm	68	68	36	36	25	25
¼" female NPT	¼" female NPT	inch	2 ¹ / ₁₆	2 ¹ / ₁₆	1 ² / ₄	1 ¹ / ₁₆	3 ³ / ₃₂	1
		mm	68	68	36	36	25	25
⅜" male NPT	¼" female NPT	inch	2 ¹ / ₁₆	2 ¹ / ₁₆	1 ² / ₄	1 ¹ / ₁₆	3 ³ / ₃₂	1
		mm	68	68	36	36	25	25

Dimensions for reference only, subject to change.

* D¹ and H¹ for valves with panel mounting.

3900 Series: Globe Pattern

Regulating and PCTFE stem tips

INLET A	OUTLET B	D	E	F		H	H ^{1*}	
				METAL STEM	PCTFE STEM			
½" Gyrolok®	½" Gyrolok®	inch	3 ⁷ / ₃₂	3 ²³ / ₃₂	2 ¹ / ₈	1 ⁷ / ₈	2 ⁵ / ₃₂	1 ¹⁹ / ₃₂
		mm	81	93	54	48	20	40
½" female NPT	½" female NPT	inch	3 ⁷ / ₃₂	2 ¹ / ₁₆	2 ¹ / ₈	1 ⁷ / ₈	2 ⁵ / ₃₂	1 ¹⁹ / ₃₂
		mm	81	68	54	48	20	40

Dimensions for reference only, subject to change.

* D¹ and H¹ for valves with panel mounting.

3700, 3800, 3900 Series

How to Order: Standard Valves

3700 Series: Globe Pattern

Vee-point stem

0.060" (1.5mm) orifice/0.07 Cv

END CONNECTIONS		ORDER BY PART NUMBER	
INLET	OUTLET	BRASS	316 STAINLESS STEEL
1/8" male NPT	1/8" male NPT	3732M2B	—
1/4" Gyrolok®	1/4" Gyrolok®	—	3732G4Y
1/4" male NPT	1/4" male NPT	3732M4B	3732M4Y

3700 Series: Globe Pattern

Blunt vee-point stem

0.170" (4.3mm) orifice/0.40 Cv

END CONNECTIONS		ORDER BY PART NUMBER	
INLET	OUTLET	BRASS	316 STAINLESS STEEL
1/8" male NPT	1/8" male NPT	3742M2B	3742M2Y
1/8" female NPT	1/8" female NPT	3742F2B	3742F2Y
1/4" Gyrolok®	1/4" Gyrolok®	3742G4B	3742G4Y
1/4" male NPT	1/4" male NPT	3742M4B	3742M4Y

3700 Series: Globe Pattern

Regulating stem tip

0.170" (4.3mm) orifice/0.35 Cv

END CONNECTIONS		ORDER BY PART NUMBER		
INLET	OUTLET	BRASS	316 STAINLESS STEEL	MONEL®
1/8" Gyrolok®	1/8" Gyrolok®	3712G2B	3712G2Y	—
1/8" male NPT	1/8" male NPT	3712M2B	3712M2Y	—
1/8" female NPT	1/8" female NPT	3712F2B	3712F2Y	—
1/4" Gyrolok®	1/4" Gyrolok®	3712G4B	3712G4Y	3712G4M
1/4" male NPT	1/4" Gyrolok®	3712H4B	3712H4Y	3712H4M
1/4" male NPT	1/4" male NPT	3712M4B	3712M4Y	—
3mm Gyrolok®	3mm Gyrolok®	—	3712G3YMM	—
6mm Gyrolok®	6mm Gyrolok®	—	3712G6YMM	—
8mm Gyrolok®	8mm Gyrolok®	—	3712G8YMM	—

3700 Series: Globe Pattern

PCTFE stem tip

0.170" (4.3mm) orifice/0.40 Cv

END CONNECTIONS		ORDER BY PART NUMBER		
INLET	OUTLET	BRASS	316 STAINLESS STEEL	MONEL®
1/8" Gyrolok®	1/8" Gyrolok®	—	3752G2Y	—
1/8" female NPT	1/8" female NPT	3752F2B	3752F2Y	—
1/4" Gyrolok®	1/4" Gyrolok®	3752G4B	3752G4Y	3752G4M
1/4" male NPT	1/4" Gyrolok®	3752H4B	3752H4Y	—
1/4" male NPT	1/4" male NPT	3752M4B	3752M4Y	—
3mm Gyrolok®	3mm Gyrolok®	—	3752G3YMM	—
6mm Gyrolok®	6mm Gyrolok®	—	3752G6YMM	—
8mm Gyrolok®	8mm Gyrolok®	—	3752G8YMM	—

3700 Series: Angle Pattern

Regulating stem tip

0.170" (4.3mm) orifice/0.35 Cv

END CONNECTIONS		ORDER BY PART NUMBER	
INLET	OUTLET	BRASS	316 STAINLESS STEEL
1/8" Gyrolok®	1/8" Gyrolok®	—	3722G2Y
1/8" male NPT	1/8" male NPT	3722M2B	—
1/8" female NPT	1/8" female NPT	3722F2B	—
1/8" male NPT	1/4" Gyrolok®	3722H24B	—
1/4" Gyrolok®	1/4" Gyrolok®	—	3722G4Y
1/4" male NPT	1/4" Gyrolok®	3722H4B	3722H4Y
1/4" male NPT	1/4" male NPT	3722M4B	3722M4Y
6mm Gyrolok®	6mm Gyrolok®	—	3722G6YMM



3712G4B: Globe pattern

FOR YOUR SAFETY

IT IS SOLELY THE RESPONSIBILITY OF THE SYSTEM DESIGNER AND USER TO SELECT PRODUCTS SUITABLE FOR THEIR SPECIFIC APPLICATION REQUIREMENTS AND TO ENSURE PROPER INSTALLATION, OPERATION AND MAINTENANCE OF THESE PRODUCTS. MATERIAL COMPATIBILITY, PRODUCT RATINGS AND APPLICATION DETAILS SHOULD BE CONSIDERED IN THE SELECTION. IMPROPER SELECTION OR USE OF PRODUCTS DESCRIBED HEREIN CAN CAUSE PERSONAL INJURY OR PROPERTY DAMAGE.



3722G4B: Angle pattern

3700, 3800, 3900 Series

How to Order: Standard Valves

3700 Series: Angle Pattern

PCTFE stem tip

0.170" (4.3mm) orifice/0.40 Cv

END CONNECTIONS		ORDER BY PART NUMBER	
INLET	OUTLET	BRASS	316 STAINLESS STEEL
¼" Gyrolok®	¼" Gyrolok®	—	3762G4Y
¼" male NPT	¼" Gyrolok®	3762H4B	3762H4Y
¼" male NPT	¼" male NPT	3762M4B	3762M4Y
6mm Gyrolok®	6mm Gyrolok®	—	3762G6YMM

3800 Series: Globe Pattern

Regulating stem tip

0.219" (5.6mm) orifice/0.55 Cv

END CONNECTIONS		ORDER BY PART NUMBER		
INLET	OUTLET	BRASS	316 STAINLESS STEEL	MONEL®
¼" male NPT	¼" female NPT	3812L4B	3812L4Y	—
¼" female NPT	¼" female NPT	3812F4B	3812F4Y	—
¼" male NPT	⅜" Gyrolok®	3812H46B	3812H46Y	3812H46M
⅜" Gyrolok®	⅜" Gyrolok®	3812G6B	3812G6Y	3812G6M
⅜" male NPT	⅜" male NPT	3812M6B	3812M6Y	—
½" Gyrolok®	½" Gyrolok®	3812G8B	3812G8Y	3812G8M
10mm Gyrolok®	10mm Gyrolok®	—	3812G10YMM	—
12mm Gyrolok®	12mm Gyrolok®	—	3812G12YMM	—



3812F4Y: Globe pattern with D-style panel mounting

3800 Series: Globe Pattern

Vee-point stem tip

0.219" (5.6mm) orifice/0.55 Cv

END CONNECTIONS		ORDER BY PART NUMBER	
INLET	OUTLET	BRASS	316 STAINLESS STEEL
⅜" Gyrolok®	⅜" Gyrolok®	3842G6B	3842G6Y
½" Gyrolok®	½" Gyrolok®	3842G8B	3842G8Y

3800 Series: Globe Pattern

PCTFE stem tip

0.170" (4.3mm) orifice/0.40 Cv

END CONNECTIONS		ORDER BY PART NUMBER	
INLET	OUTLET	BRASS	316 STAINLESS STEEL
¼" male NPT	¼" female NPT	—	3852L4Y
¼" female NPT	¼" female NPT	3852F4B	3852F4Y
⅜" Gyrolok®	⅜" Gyrolok®	—	3852G6Y
⅜" male NPT	⅜" male NPT	—	3852M6Y
½" Gyrolok®	½" Gyrolok®	—	3852G8Y
10mm Gyrolok®	10mm Gyrolok®	—	3852G10YMM
12mm Gyrolok®	12mm Gyrolok®	—	3852G12YMM



3862L4Y: Angle pattern

3800 Series: Angle Pattern

Regulating stem tip

0.170" (4.3mm) orifice/0.55 Cv

END CONNECTIONS		ORDER BY PART NUMBER	
INLET	OUTLET	BRASS	316 STAINLESS STEEL
¼" male NPT	¼" female NPT	—	3802L4Y
¼" female NPT	¼" female NPT	3802F4B	3802F4Y
⅜" male NPT	¼" female NPT	—	3802L64Y

3800 Series: Angle Pattern

PCTFE stem tip

0.170" (4.3mm) orifice/0.55 Cv

END CONNECTIONS		ORDER BY PART NUMBER	
INLET	OUTLET	BRASS	316 STAINLESS STEEL
¼" male NPT	¼" female NPT	—	3862L4Y
¼" female NPT	¼" female NPT	3862F4B	3862F4Y
⅜" male NPT	¼" female NPT	—	3862L64Y

FOR YOUR SAFETY

IT IS SOLELY THE RESPONSIBILITY OF THE SYSTEM DESIGNER AND USER TO SELECT PRODUCTS SUITABLE FOR THEIR SPECIFIC APPLICATION REQUIREMENTS AND TO ENSURE PROPER INSTALLATION, OPERATION AND MAINTENANCE OF THESE PRODUCTS. MATERIAL COMPATIBILITY, PRODUCT RATINGS AND APPLICATION DETAILS SHOULD BE CONSIDERED IN THE SELECTION. IMPROPER SELECTION OR USE OF PRODUCTS DESCRIBED HEREIN CAN CAUSE PERSONAL INJURY OR PROPERTY DAMAGE.

3700, 3800, 3900 Series

How to Order: Standard Valves

3900 Series: Globe Pattern*

Regulating stem tip

0.312" (7.9mm) orifice/1.1 Cv

END CONNECTIONS		ORDER BY PART NUMBER		
INLET	OUTLET	BRASS	316 STAINLESS STEEL	CARBON STEEL
½" Gyrolok®	½" Gyrolok®	—	3912G8Y	—
½" female NPT	½" female NPT	3912F8B	3912F8Y	3912F8E

* 3912 series only available with metal handle

3900 Series: Globe Pattern

PCTFE stem tip

0.312" (7.9mm) orifice/1.1 Cv

END CONNECTIONS		ORDER BY PART NUMBER		
INLET	OUTLET	BRASS	316 STAINLESS STEEL	CARBON STEEL
½" Gyrolok®	½" Gyrolok®	—	3952G8Y	—
½" female NPT	½" female NPT	3952F8B	3952F8Y	3952F8E



3952F8Y: Globe pattern

Ordering Options

Handle Options*

To order a plug button, specify a part number from below.

COLOR	3712, 3722, 3732, 3742, 3752, 3762, 3802, 3852, 3862 SERIES	3812, 3842, 3952 SERIES
Red	94312-002	94349-002
Green	94312-003	94349-003
Yellow	94312-004	94349-004
Orange	94312-005	94349-005
Brown	94312-006	94349-006
Blue	94312-007	94349-007

* 3912 series is not available with plug button

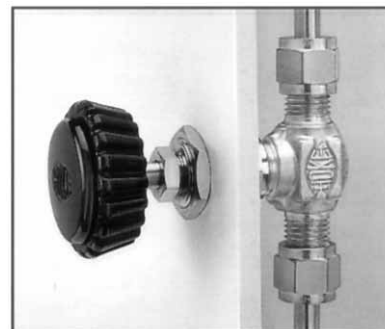

D-style panel mounting

O-ring Packing

O-ring packing is available for all 3700 and 3800 Series valves. For Buna-N o-ring packing, specify kit number 3700K1. For Viton® o-ring packing, specify kit number 3700K2. For additional o-ring options, contact your local HOKE distributor.

Panel Mounting

3700 & 3800 Series

D-style: HOKE's factory-installed panel mounting permits valve installation without disrupting the packing. In addition, future packing adjustments may be performed while the valve is mounted. Factory-installed panel mount D-style is available for all models except the 3732 Series (globe pattern, vee-point stem). To order, add a 'D' prefix to the model number (e.g., D3712G4Y)

P-style: Panel mounting kits may be field installed on all 3700 and 3800 Series valves (including the 3732 Series). Once the kit is in place, valves may be mounted without disrupting the packing. All future packing adjustments must be performed with the valve removed from the panel. To order, specify part number 306-86A, which contains one kit.



P-style panel mounting kits

Panel mounting dimensions for 3700 & 3800 Series

Panel hole = ¼" (16.2 mm) diameter

Panel thickness = $\frac{3}{16}$ " (4.7 mm) maximum

3900 Series

P-style panel mounting kits for field installation are available. To order, specify kit number 3900K1

Panel mounting dimensions for 3900 Series

Panel hole = $\frac{4}{16}$ " (19.4 mm) diameter

Panel thickness = $\frac{5}{16}$ " (7.9 mm) maximum

Spare Parts

Spare parts and repair kits are available for all needle valves. Please contact your distributor for specific information.

Cleaning and Testing

When ordering, please specify if oxygen cleaning or helium leak testing is required.

Additional Sizes

Additional sizes and options are available on special request. Please consult your local HOKE distributor.

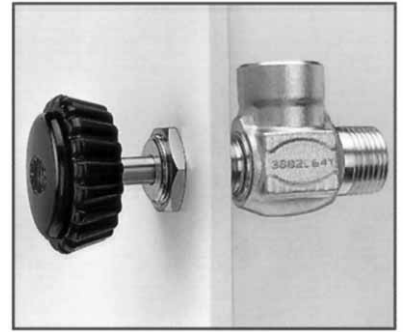

P-style panel mounting

For Your Safety

It is solely the responsibility of the system designer and user to select products suitable for their specific application requirements and to ensure proper installation, operation, and maintenance of these products. Material compatibility, product ratings and application details should be considered in the selection. Improper selection or use of products described herein can cause personal injury or property damage.

*Grafoil® is a registered trademark of UCAR Carbon Company, Inc.
GRAPH-LOCK® is a registered trademark of Garlock Sealing Technologies.
Gyrolok® and Dyna-Pak® are registered trademarks of HOKE Incorporated.
Hastelloy® is a registered trademark of Haynes International, Inc.
Monel® is a registered trademark of Special Metals Corporation.
Viton® is a registered trademark of DuPont Dow Elastomers*

www.ucar.com
www.garlock.com
www.hoke.com
www.haynesintl.com
www.specialmetals.com
www.dupont-dow.com

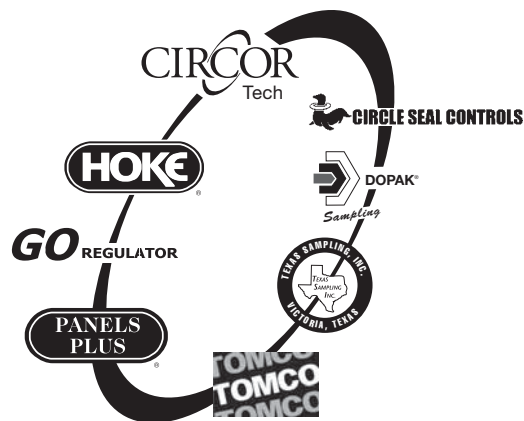

Hoke • GO Regulator • Tomco • CIRCOR Tech

405 Centura Court • PO Box 4866 (29305)

Spartanburg, SC 29303

Tel (864) 574-7966 • Fax (864) 587-5608

www.circortechnologies.com

Hoke Controls / Panels Plus

2054 Francis St.
Ontario, CA 91761
Tel (909) 923-3770
Fax (909) 923-2550
www.circor-panelsplus.com

Dopak Inc.

9572 Kempwood
Houston, Texas 77080
Tel (713) 460-8311
Fax (713) 460-8578
www.dopak.com

Texas Sampling, Inc

3706 Rio Grande
Victoria, Texas 77901
Tel (361) 575-8087
Fax (361) 575-8157
www.texassampling.com

Circle Seal Controls

2301 Wardlow Circle
Corona, CA 92880
Tel (951) 270-6200
Fax (951) 270-6201
www.circlesealcontrols.com

**CIRCOR Instrumentation Technologies
Central Europe**

Leeuwenhoekweg 24
2661 CZ Bergschenhoek
The Netherlands
Tel +31 10 4206011 • Fax +31 10 4566774
www.circortechnologies.com

Hoke GmbH

Weitzesweg 11
Postfach 1541
D-61118 Bad Vilbel-Dortelweil
Germany
Tel +49 6101 82 56 0
Fax +49 6101 82 56 40
www.hoke.de

CIRCOR Instrumentation Technologies

CIRCOR Instrumentation Technologies (CIT) is a product group of CIRCOR International (NYSE: CIR), specializing in fluid process control solutions with orifice sizes typically up to 1". Our main product lines include ball, needle, packless, diaphragm, solenoid, and metering valves, pressure regulators, quick couplers, Gyrolok® compression tube fittings, and fully integrated sampling systems.

CIT markets primarily to the petrochemical, refining, power generation, food and beverage, semiconductor, and pharmaceutical industries, and to OEM's. CIT separates itself from the competition by offering highly engineered components manufactured to exacting standards and a variety of custom options.