



7G Series

2- and 3-way Ball Valves
Multi-directional Flow



instrumentation ball valves

HOKE Inc.
405 Centura Court • PO Box 4866 (29305) • Spartanburg, SC 29303
Phone (864) 574-7966 Fax (864) 587-5608
www.hoke.com • sales@hoke.com



7G Series

2- and 3-way Ball Valves
Multi-directional Flow



instrumentation ball valves

Typical Applications

- Hydraulic test stands
- High pressure test stands
- Viscous media handling
- Gas and liquid applications
- Pilot plants in refineries and chemical plants
- Measurement and regulating equipment

Technical Data

BODY MATERIAL	316 stainless steel
MAXIMUM OPERATING PRESSURE	3000 psig (207 barg)
PROOF PRESSURE SAFETY FACTOR	2:1
BURSTING PRESSURE SAFETY FACTOR	4:1
TEMPERATURE RANGE	-20°F to +475° F (-29°C to +232° C)
ORIFICE SIZES	0.156" (4mm) to 0.316" (8mm)
INSTRUMENT PANEL DIAMETER*	0.80" (20mm)
INSTRUMENT PANEL THICKNESS*	0.24" (6mm)

* Panel mount not available for 1/2" and 18mm fittings

** Contact factory for other seat materials

Features

- Floating ball valve provides shut off or controls flow directions (3-way)
- Panel mounting is standard for all end fitting sizes except 1/2" and 18mm end connections
- Reliable housing construction incorporates metal seals
- Dyna-Pak® packing provides a leak-tight seal with low operating torque in vacuum or high pressure applications, helping to prevent fugitive emissions
- Handle points to port in use or to closed position, providing a visual cue and improved safety
- Multi-directional flow throughout entire operating pressure range
- Fractional Gyrolok and female NPT end fittings up to 1/2"; metric Gyrolok up to 18mm
- Pressure assisted sealing, no sealing adjustment required
- Virgin TFE seat and seal design**
- Special High Tolerance NPT Thread

HOKE Inc.

405 Centura Court • PO Box 4866 (29305) • Spartanburg, SC 29303
Phone (864) 574-7966 Fax (864) 587-5608
www.hoke.com • sales@hoke.com

7G 2-way Ball Valves

Bi-directional Flow

Materials and Dimensions

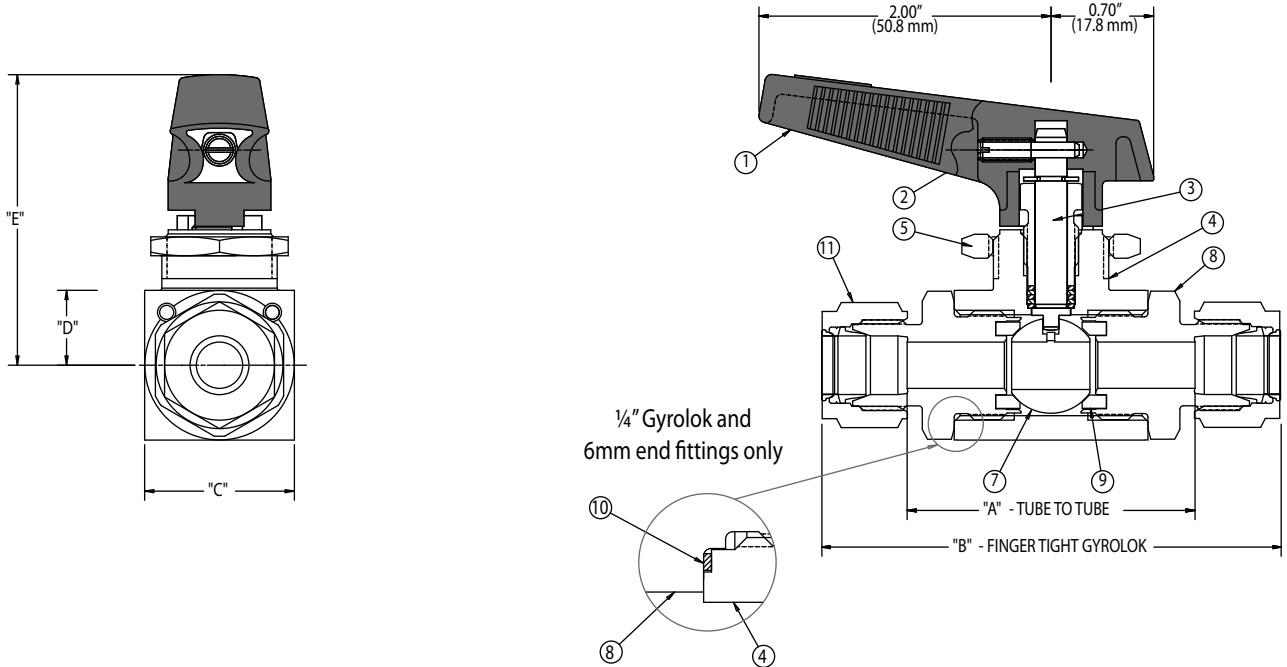

Materials of Construction

	DESCRIPTION	MATERIAL
1	RED LEVER HANDLE	Nylon
2	HANDLE PIN	316 stainless steel
3	STEM ASSEMBLY	316 stainless steel, Teflon®
4	BODY	316 stainless steel
5	PANEL NUT	316 stainless steel
6	PIN	316 stainless steel
7	BALL	316 stainless steel
8	END FITTING	316 stainless steel
9	SEAT	Virgin TFE
10	WASHER*	316 stainless steel
11	NUT & FERRULE SET	316 stainless steel

* 1/4" Gyrolok and 6mm end fittings only

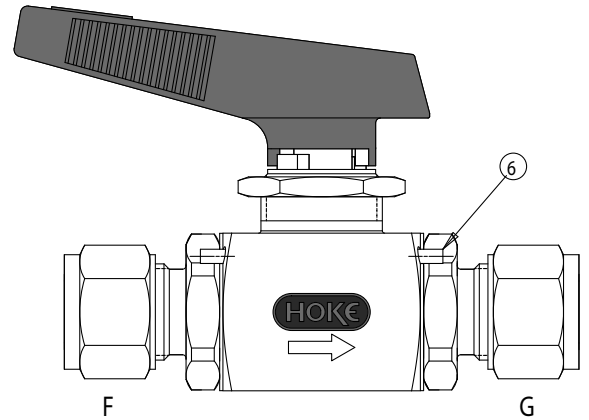

Dimensions

INLET F / OUTLET G	A	B	C	D	E	ORIFICE	CV
1/4" FEMALE NPT	NA	2.08 (53mm)	1.02 (26mm)	0.51 (13mm)	2.01 (51mm)	0.316 (8.0mm)	2.45
3/8" FEMALE NPT	NA	2.78 (71mm)	1.02 (26mm)	0.51 (13mm)	2.01 (51mm)	0.316 (8.0mm)	2.45
1/2" FEMALE NPT	NA	3.22 (82mm)	1.02 (26mm)	0.51 (13mm)	2.01 (51mm)	0.316 (8.0mm)	2.45
1/4" GYROLOK	1.97 (50mm)	3.24 (82mm)	.87 (22mm)	0.43 (11mm)	1.92 (49mm)	0.187 (4.8mm)	0.80
3/8" GYROLOK	2.01 (51mm)	3.43 (87mm)	1.02 (26mm)	0.51 (13mm)	2.01 (51mm)	0.282 (7.2mm)	1.12
1/2" GYROLOK	1.84 (47mm)	3.80 (96mm)	1.02 (26mm)	0.51 (13mm)	2.01 (51mm)	0.316 (8.0mm)	2.45
6mm GYROLOK	1.98 (50mm)	3.24 (82mm)	0.87 (22mm)	0.51 (13mm)	1.92 (49mm)	0.156 (4.0mm)	0.53
8mm GYROLOK	2.02 (51mm)	3.31 (84mm)	1.02 (26mm)	0.43 (11mm)	2.01 (51mm)	0.316 (8.0mm)	2.45
10mm GYROLOK	1.97 (50mm)	3.36 (85mm)	1.02 (26mm)	0.51 (13mm)	2.01 (51mm)	0.316 (8.0mm)	2.45
12mm GYROLOK	1.79 (46mm)	3.65 (93mm)	1.02 (26mm)	0.51 (13mm)	2.01 (51mm)	0.316 (8.0mm)	2.45
18mm GYROLOK	1.87 (47mm)	3.92 (100mm)	1.02 (26mm)	0.51 (13mm)	2.01 (51mm)	0.316 (8.0mm)	2.45

7G 3-way Ball Valves

Multi-directional Flow

Materials and Dimensions

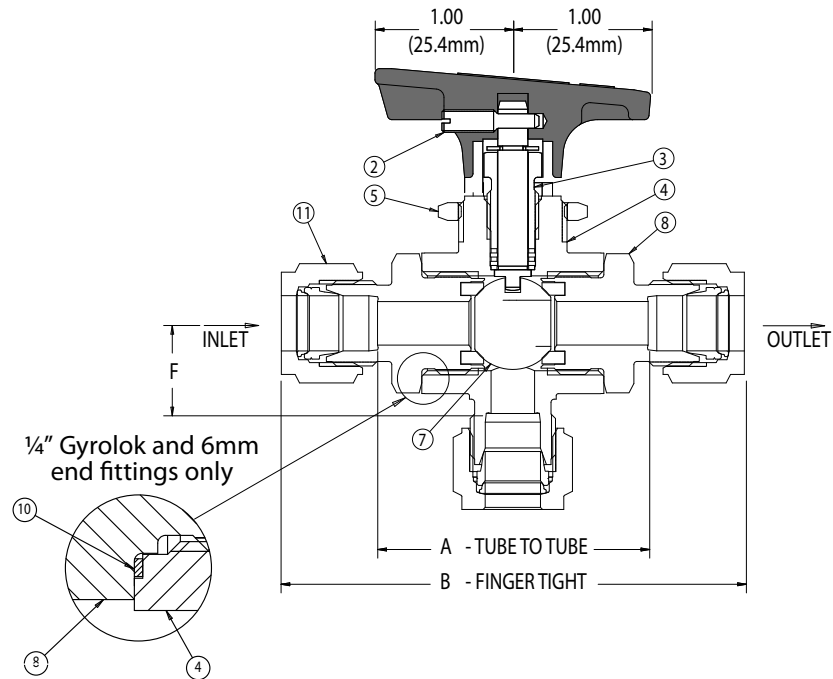

Materials of Construction

	DESCRIPTION	MATERIAL
1	LEVER HANDLE	Nylon
2	HANDLE PIN	316 stainless steel
3	STEM ASSEMBLY	316 stainless steel, Teflon®
4	BODY	316 stainless steel
5	PANEL NUT	316 stainless steel
6	PIN	316 stainless steel
7	BALL	316 stainless steel
8	END FITTING	316 stainless steel
9	SEAT	Virgin TFE
10	WASHER*	316 stainless steel
11	NUT & FERRULE SET	316 stainless steel

* 1/4" Gyrolok and 6mm end fittings only

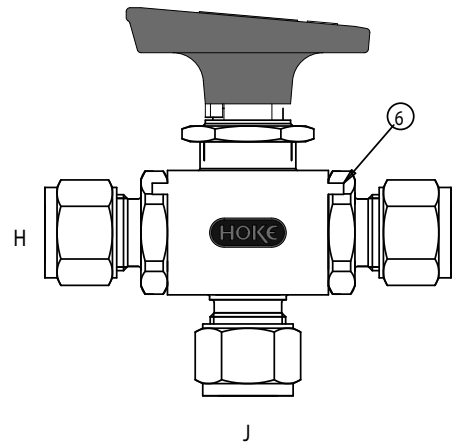

Dimensions

INLET H / OUTLET J	A	B	C	D	E	ORIFICE	Cv
1/4" FEMALE NPT	NA	2.08 (53mm)	1.02 (26mm)	0.51 (13mm)	2.01 (51mm)	0.316 (8.0mm)	2.45
3/8" FEMALE NPT	NA	2.78 (71mm)	1.02 (26mm)	0.51 (13mm)	2.01 (51mm)	0.316 (8.0mm)	2.45
1/2" FEMALE NPT	NA	3.22 (82mm)	1.02 (26mm)	0.51 (13mm)	2.01 (51mm)	0.316 (8.0mm)	2.45
1/4" GYROLOK	1.97 (50mm)	3.24 (82mm)	0.87 (22mm)	0.43 (11mm)	1.92 (49mm)	0.187 (4.8mm)	0.80
3/8" GYROLOK	2.01 (51mm)	3.43 (87mm)	1.02 (26mm)	0.51 (13mm)	2.01 (51mm)	0.282 (7.2mm)	1.12
1/2" GYROLOK	1.84 (47mm)	3.80 (96mm)	1.02 (26mm)	0.51 (13mm)	2.01 (51mm)	0.316 (8.0mm)	2.45
6mm GYROLOK	1.98 (50mm)	3.24 (82mm)	0.87 (22mm)	0.51 (13mm)	1.92 (49mm)	0.156 (4.0mm)	0.53
8mm GYROLOK	2.02 (51mm)	3.31 (84mm)	1.02 (26mm)	0.43 (11mm)	2.01 (51mm)	0.316 (8.0mm)	2.45
10mm GYROLOK	1.97 (50mm)	3.36 (85mm)	1.02 (26mm)	0.51 (13mm)	2.01 (51mm)	0.316 (8.0mm)	2.45
12mm GYROLOK	1.79 (46mm)	3.65 (93mm)	1.02 (26mm)	0.51 (13mm)	2.01 (51mm)	0.316 (8.0mm)	2.45
18mm GYROLOK	1.87 (47mm)	3.92 (100mm)	1.02 (26mm)	0.51 (13mm)	2.01 (51mm)	0.316 (8.0mm)	2.45

7G 2- and 3-way Ball Valves

Multi-directional Flow

Pressure Temperature Curve

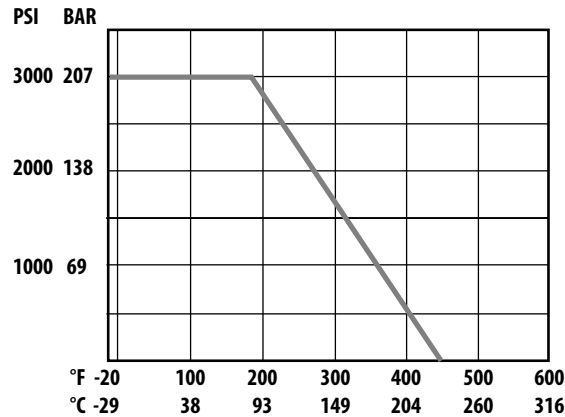

Dyna-Pak® Stem Packing

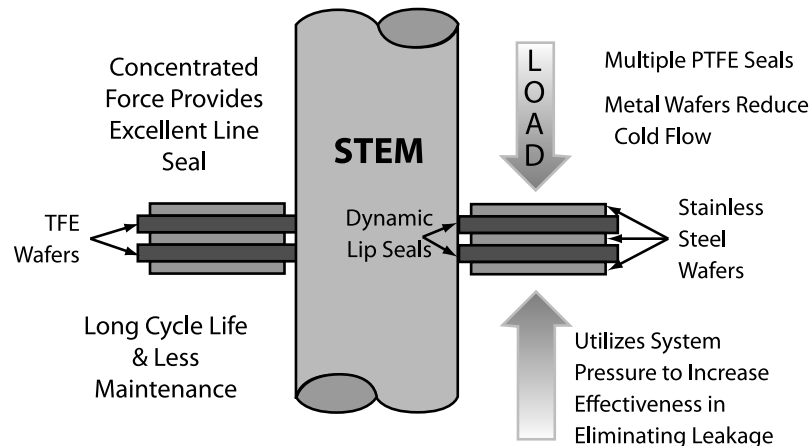

How to Order

7G2 210 F4 Y MM

Valve Series

- 7G2** 2-way
- 7G4** 3-way

Metric

MM Specify for Gyrolok® metric only*
(fractional sizes leave blank)

Inlet/Outlet

- F4** 1/4" female NPT
- F6** 3/8" female NPT
- F8** 1/2" female NPT
- G4** 1/4" Gyrolok
- G6** 3/8" Gyrolok
- G8** 1/2" Gyrolok
- G6** 6mm Gyrolok
- G8** 8mm Gyrolok
- G10** 10mm Gyrolok
- G12** 12mm Gyrolok
- G18** 18mm Gyrolok (2-way Only)

FOR YOUR SAFETY

IT IS SOLELY THE RESPONSIBILITY OF THE SYSTEM DESIGNER AND USER TO SELECT PRODUCTS SUITABLE FOR THEIR SPECIFIC APPLICATION REQUIREMENTS AND TO ENSURE PROPER INSTALLATION, OPERATION AND MAINTENANCE OF THESE PRODUCTS. MATERIAL COMPATIBILITY, PRODUCT RATINGS AND APPLICATION DETAILS SHOULD BE CONSIDERED IN THE SELECTION. IMPROPER SELECTION OR USE OF PRODUCTS DESCRIBED HEREIN CAN CAUSE PERSONAL INJURY OR PROPERTY DAMAGE.

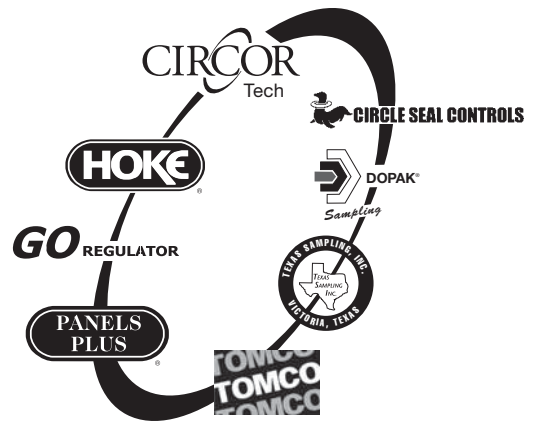
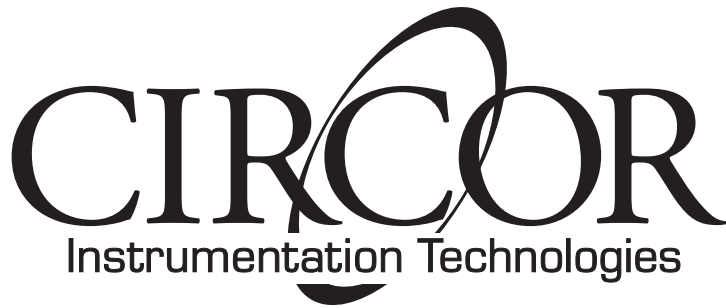

Hoke • GO Regulator • Tomco • CIRCOR Tech

405 Centura Court • PO Box 4866 (29305)

Spartanburg, SC 29303

Tel (864) 574-7966 • Fax (864) 587-5608

www.circortechnologies.com

Hoke Controls / Panels Plus

2054 Francis St.

Ontario, CA 91761

Tel (909) 923-3770

Fax (909) 923-2550

www.circor-panelsplus.com

Dopak Inc.

9572 Kempwood

Houston, Texas 77080

Tel (713) 460-8311

Fax (713) 460-8578

www.dopak.com

Texas Sampling, Inc

3706 Rio Grande

Victoria, Texas 77901

Tel (361) 575-8087

Fax (361) 575-8157

www.texassampling.com

Circle Seal Controls

2301 Wardlow Circle

Corona, CA 92880

Tel (951) 270-6200

Fax (951) 270-6201

www.circlesealcontrols.com

CIRCOR Instrumentation

Technologies

Central Europe

Leeuwenhoekweg 24

2661 CZ Bergschenhoek

The Netherlands

Tel +31 10 4206011 • Fax +31 10 4566774

www.circortechnologies.com

Hoke GmbH

Weitzesweg 11

Postfach 1541

D-61118 Bad Vilbel-Dortelweil

Germany

Tel +49 6101 82 56 0

Fax +49 6101 82 56 40

www.hoke.de

CIRCOR Instrumentation Technologies

CIRCOR Instrumentation Technologies (CIT) is a product group of CIRCOR International (NYSE: CIR), specializing in fluid process control solutions with orifice sizes typically up to 1". Our main product lines include ball, needle, packless, diaphragm, solenoid, and metering valves, pressure regulators, quick couplers, Gyrolok® compression tube fittings, and fully integrated sampling systems.

CIT markets primarily to the petrochemical, refining, power generation, food and beverage, semiconductor, and pharmaceutical industries, and to OEM's. CIT separates itself from the competition by offering highly engineered components manufactured to exacting standards and a variety of custom options.