

O-ring Male Adapter: AOM

connects fractional port to female NPT threads

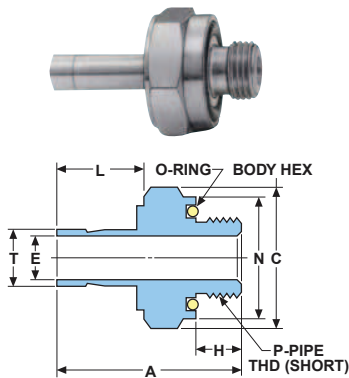

Part Number*	T P		Dimensions — inches							O-ring	
	Tube O.D.	Pipe Size	A	Hex Flat	E min	H	L	N	I.D.	O.D.	
1AOM2[]	1/16	1/8	1.03	3/4	.03	.28	.47	.75	7/16	5/8	
2AOM2[]	1/8	1/8	1.23	3/4	.09	.28	.63	.75	7/16	5/8	
2AOM4[]	1/8	1/4	1.36	15/16	.09	.38	.63	.94	9/16	3/4	
3AOM2[]	3/16	1/8	1.25	3/4	.13	.28	.66	.75	7/16	5/8	
3AOM4[]	3/16	1/4	1.38	15/16	.13	.38	.66	.94	9/16	3/4	
4AOM2[]	1/4	1/8	1.31	3/4	.13	.28	.69	.75	7/16	5/8	
4AOM4[]	1/4	1/4	1.44	15/16	.19	.38	.69	.94	9/16	3/4	
4AOM6[]	1/4	3/8	1.50	1 1/8	.19	.41	.69	1.13	3/4	15/16	
6AOM2[]	3/8	1/8	1.38	3/4	.25	.28	.78	.75	7/16	5/8	
6AOM4[]	3/8	1/4	1.52	15/16	.28	.38	.78	.94	9/16	3/4	

O-ring Male Adapter: AOM/ME

connects metric port to female NPT threads

Part Number*	T P		Dimensions — mm							O-ring	
	Tube O.D.	Pipe Size	A	Hex Flat	E min	H	L	N	I.D.	O.D.	
6AOM2[]ME	6	1/8	32.8	19.1	4.4	7.3	17.3	18.6	11.5	16.6	
6AOM4[]ME	6	1/4	37.6	23.8	4.4	9.7	17.3	23.4	14.7	19.7	
10AOM4[]ME	10	1/4	40.1	23.8	7.0	9.7	19.8	23.4	14.7	19.7	
10AOM6[]ME	10	3/8	40.9	28.6	7.5	10.4	19.8	28.1	19.4	24.5	
12AOM6[]ME	12	3/8	45.2	28.6	9.1	10.4	24.5	28.1	19.4	24.3	
12AOM8[]ME	12	1/2	50.8	33.3	9.1	13.6	24.4	32.9	25.6	25.9	

O-ring Straight Adapter: AOS

connects fractional port to female O-ring straight thread

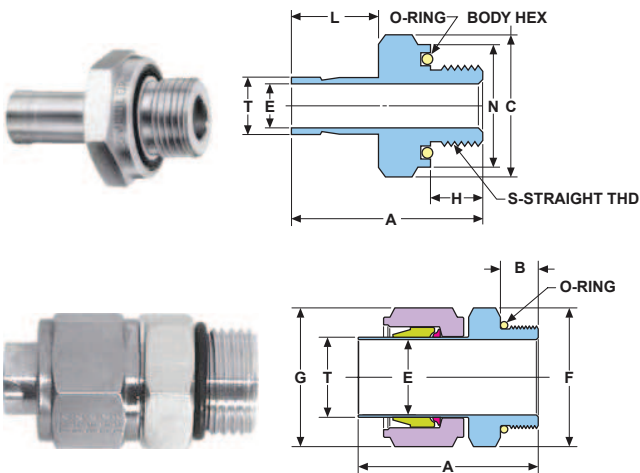

Part Number*	T S		Dimensions — inches							O-ring	
	Tube O.D.	Thd. Size	A	Hex Flat	E min.	H	L	N	I.D.	O.D.	
1AOS[]	1/16	5/16-24	1.06	9/16	.03	.34	.47	.56	.31	.44	
2AOS[]	1/8	5/16-24	1.25	9/16	.09	.34	.63	.56	.31	.44	
3AOS[]	3/16	3/8-24	1.34	5/8	.13	.38	.66	.63	.38	.50	
4AOS[]	1/4	7/16-20	1.44	3/4	.19	.41	.69	.75	.44	.63	
6AOS[]	3/8	9/16-18	1.61	15/16	.28	.47	.78	.94	.56	.75	
8AOS[]	1/2	3/4-16	1.84	1 1/8	.39	.47	.97	1.13	.75	.94	

Male SAE Adapter: AMS

connects fractional port to SAE/MS straight thread boss

Part Number	Dimensions—inches							O-ring
	T Tube O.D.	S	A	B	E	F	G	
20AMS20316	1 1/4	1 5/8-12	2.81	.59	1.17	1 7/8	1.88	-920
24AMS24316	1 1/2	1 7/8-12	3.28	.59	1.30	2 1/8	2.25	-924
32AMS32316	2	2 1/2-12	4.24	.59	1.75	2 3/4	3	-932