

Male Elbow: LM

connects fractional tube to female NPT thread

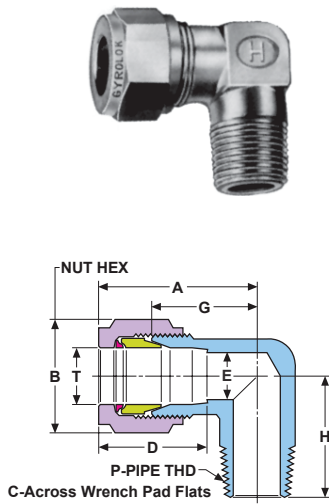

Part Number*	T		P		Dimensions — inches					
	Tube O.D.	Male NPT Size	A	Hex Flat	B	C	D	E min	G	H
1LM1[]	1/16	1/16	.78	5/16	7/16	.41	.05	.56	.72	
1LM2[]	1/16	1/8	.78	5/16	7/16	.41	.05	.56	.88	
2LM1[]	1/8	1/16	.97	7/16	7/16	.56	.09	.66	.72	
2LM2[]	1/8	1/8	.97	7/16	7/16	.56	.09	.66	.72	
2LM4[]	1/8	1/4	1.09	7/16	1/2	.56	.09	.78	.94	
3LM2[]	3/16	1/8	1	1/2	7/16	.59	.13	.69	.75	
3LM4[]	3/16	1/4	1	1/2	1/2	.59	.13	.72	.94	
4LM2[]	1/4	1/8	1.05	9/16	7/16	.64	.19	.72	.78	
4LM4[]	1/4	1/4	1.11	9/16	1/2	.64	.19	.78	1	
4LM6[]	1/4	3/8	1.20	9/16	11/16	.64	.19	.88	1.13	
4LM8[]	1/4	1/2	1.33	9/16	13/16	.64	.42	1	1.25	
6LM2[]	3/8	1/8	1.19	11/16	1/2	.72	.19	.84	.88	
6LM4[]	3/8	1/4	1.19	11/16	1/2	.72	.30	.84	1	
6LM6[]	3/8	3/8	1.28	11/16	11/16	.72	.30	.94	1.13	
6LM8[]	3/8	1/2	1.38	11/16	13/16	.72	.30	1.03	1.25	
8LM4[]	1/2	1/4	1.44	7/8	11/16	.97	.30	.97	1.13	
8LM6[]	1/2	3/8	1.44	7/8	11/16	.97	.41	.97	1.13	
8LM8[]	1/2	1/2	1.50	7/8	11/16	.97	.42	1.03	1.31	
8LM12[]	1/2	3/4	1.56	7/8	1	.97	.72	1.06	1.50	
10LM6[]	5/8	3/8	1.47	1	13/16	1	.41	1.03	1.25	
10LM8[]	5/8	1/2	1.47	1	13/16	1	.50	1.03	1.38	
12LM8[]	3/4	1/2	1.59	1 1/8	1	1	.50	1.16	1.50	
12LM12[]	3/4	3/4	1.59	1 1/8	1	1	.66	1.16	1.50	
14LM12[]	7/8	3/4	1.72	1 1/4	1 1/4	1.06	.72	1.28	1.50	
16LM12[]	1	3/4	1.88	1 1/2	1 1/4	1.31	.72	1.31	1.66	
16LM16[]	1	1	1.88	1 1/2	1 1/4	1.31	.88	1.31	1.84	
20LM20[]	1 1/4	1 1/4	2.62	1 7/8	1 11/16	1.53	1.09	1.75	1.88	
24LM24[]	1 1/2	1 1/2	3.07	2 1/4	2	1.78	1.34	2	2.38	
32LM32[]	2	2	4.22	3	2 3/4	2.47	1.81	2.75	2.78	

Male Elbow: LM/ME, LM/MC

connects metric tube with NPT or RT tapered threads

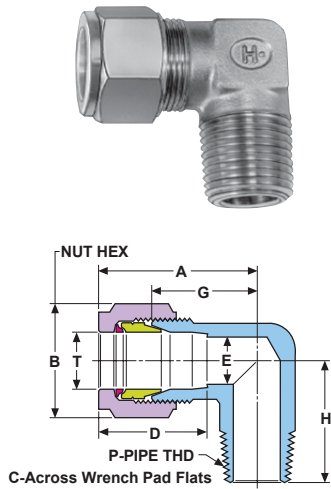

Part Number*	T		P		Dimensions — mm							
	NPT Threads	RT Threads	Tube O.D.	Male NPT Size	A	Hex Flat	B	C	D	E min	G	H
3LM2[]ME	3LM2[]MC	3	1/8	24.7	11.1	11.0	14.3	2.2	16.8	19.8		
3LM4[]ME	3LM4[]MC	3	1/4	27.8	11.1	13.7	14.3	2.2	19.8	23.8		
4LM2[]ME	4LM2[]MC	4	1/8	25.3	12.7	11.7	15.1	2.3	17.5	19.1		
4LM4[]ME	4LM4[]MC	4	1/4	25.3	12.7	13.7	15.1	2.3	17.5	23.8		
6LM2[]ME	6LM2[]MC	6	1/8	26.3	14.3	11.7	16.3	3.8	18.3	19.8		
6LM4[]ME	6LM4[]MC	6	1/4	28.2	14.3	13.7	16.3	3.8	19.8	25.4		
6LM6[]ME	6LM6[]MC	6	3/8	30.6	14.3	17.2	16.3	3.8	22.2	28.6		
6LM8[]ME	6LM8[]MC	6	1/2	33.8	14.3	21.3	16.3	3.8	25.4	31.8		
8LM2[]ME	8LM2[]MC	8	1/8	28.6	15.9	12.7	16.7	5.8	20.6	22.2		
8LM4[]ME	8LM4[]MC	8	1/4	28.6	15.9	13.7	16.7	5.8	20.6	25.4		
8LM6[]ME	8LM6[]MC	8	3/8	31.0	15.9	17.2	16.7	5.8	23.0	28.6		
8LM8[]ME	8LM8[]MC	8	1/2	34.2	15.9	21.4	16.7	5.8	26.2	31.8		
10LM2[]ME	10LM2[]MC	10	1/8	31.9	19.1	17.5	17.5	4.6	23.9	23.9		
10LM4[]ME	10LM4[]MC	10	1/4	32.6	19.1	17.8	17.5	7.1	24.6	28.7		
10LM6[]ME	10LM6[]MC	10	3/8	31.8	19.1	17.2	17.5	7.9	28.8	28.6		
10LM8[]ME	10LM8[]MC	10	1/2	34.1	19.1	21.3	17.5	7.9	26.2	31.8		
12LM4[]ME	12LM4[]MC	12	1/4	36.6	22.2	17.8	24.6	7.1	24.6	28.6		
12LM6[]ME	12LM6[]MC	12	3/8	36.6	22.2	17.8	24.6	9.9	24.6	28.7		
12LM8[]ME	12LM8[]MC	12	1/2	38.1	22.2	21.3	24.6	9.9	26.2	33.3		
12LM12[]ME	12LM12[]MC	12	3/4	41.3	22.2	26.7	24.6	9.9	29.4	38.1		
14LM6[]ME	14LM6[]MC	14	3/8	35.6	23.8	20.6	22.2	10.2	26.2	30.6		
14LM8[]ME	14LM8[]MC	14	1/2	35.6	23.8	22.6	22.2	11.9	26.2	33.3		
15LM8[]ME	15LM8[]MC	15	1/2	36.5	23.8	20.7	22.2	12.7	26.2	31.8		
16LM6[]ME	16LM6[]MC	16	3/8	37.3	25.4	20.6	25.0	10.2	26.2	32.2		
16LM8[]ME	16LM8[]MC	16	1/2	37.3	25.4	21.5	25.0	12.7	26.2	33.3		
16LM12[]ME	16LM12[]MC	16	3/4	40.6	25.4	26.7	25.0	12.7	29.5	38.1		
18LM8[]ME	18LM8[]MC	18	1/2	39.5	28.6	24.9	25.4	12.7	29.5	38.1		
18LM12[]ME	18LM12[]MC	18	3/4	39.3	28.6	25.4	25.4	15.8	29.4	38.1		
20LM8[]ME	20LM8[]MC	20	1/2	46.4	31.8	31.8	31.0	12.7	32.5	38.1		
20LM12[]ME	20LM12[]MC	20	3/4	46.4	31.8	31.8	31.0	16.7	32.5	39.4		
22LM8[]ME	22LM8[]MC	22	1/2	43.7	31.8	31.8	27.0	12.6	32.5	38.1		
22LM12[]ME	22LM12[]MC	22	3/4	44.5	31.8	31.8	27.0	17.9	33.3	41.7		
22LM16[]ME	22LM16[]MC	22	1	43.7	31.8	33.3	27.0	17.9	32.5	46.7		
25LM12[]ME	25LM12[]MC	25	3/4	47.7	38.1	31.8	33.3	18.1	33.3	42.2		
25LM16[]ME	25LM16[]MC	25	1	47.7	38.1	33.3	33.3	21.7	33.3	46.7		

* [] see page 6 for material specifications.