



2300 Series

Bar Stock Metering Valves



Typical Applications

- Metering liquids and gases on analytical equipment
- Laboratory sampling
- Gas chromatography, analyzers
- Flow meters and gauges

Technical Data

BODY*	316 stainless steel, brass
MAXIMUM OPERATING PRESSURE	<i>Brass</i> <ul style="list-style-type: none">• 3000 psig up to 200° F (207 bar @ 93° C) <i>316 stainless steel</i> <ul style="list-style-type: none">• 3000 psig 100° F (207 bar @ 38° C)• 1000 psig 250° F (68.9 bar @ 121° C)
OPERATING TEMPERATURE RANGE	<i>Buna N O-ring Packing</i> <ul style="list-style-type: none">• -40° to 200° F (-40° to 93° C) <i>Teflon® Packing</i> <ul style="list-style-type: none">• -60° to 250° F (-51° to 121° C)
ORIFICE	.062", .125" (1.59 mm, 3.17 mm)
CV FACTOR**	1° stem, 0.062" orifice: 0.012 8° stem, 0.062" orifice: 0.086 8° stem, 0.125" orifice: 0.30

* Consult factory for other materials

** Cv factors shown are based on flow through entire metering range, approximately 20 handle turns

Features & Benefits

- Micrometer vernier handle provides visual control and precise establishment of flow settings. To order, specify 2300K1 following the valve number.
- 20 turn stem displacement for fine metering
- 2 orifice sizes 0.062" (1.59mm) and 0.125" (3.17mm) are available with standard 8° stem
- Spring loaded stem in all 316 stainless steel valves prevents galling and enlargement of the orifice.
- For ultra fine metering, a 1° spring loaded stem design is available for all valves with 0.062" (1.59mm) orifice. See flow curves for details.
- Panel mounting is standard on all valves
- Bonnet lock prevents accidental disengagement of bonnet.
- Special High Tolerance NPT Thread

metering valves

HOKE Incorporated

405 Centura Court • PO Box 4866 • Spartanburg, SC 29303

Phone (864) 574-7966 Fax (864) 587-5608

www.hoke.com • sales@hoke.com

2300 Series

Materials of Construction

316 Stainless Steel Valves (Teflon® Packing)

	DESCRIPTION	MATERIAL
1	CAP NUT (10-24)	Zinc Alloy
2	HAND WHEEL*	Nylon
3	WASHER	Teflon®
4	PACKING	Teflon®
5	PACKING NUT	316 stainless
6	MOUNTING NUT	316 stainless
7	HOUSING	316 stainless
8	BODY	316 stainless
9	SPINDLE POINT	316 stainless
10	SEAT	PCTFE
11	SEAT HOLDER	316 stainless
12	BALL	316 stainless
13	COMPRESSION SPRING	316 stainless
14	STEM	316 stainless

* Optional micrometer handle - Aluminum

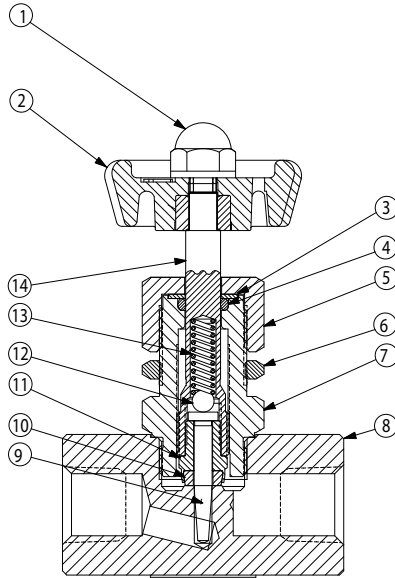

2335F[JY / 2315F[JY
stainless steel

Brass Valves (Buna-N Packing)

	DESCRIPTION	MATERIAL
1	CAP NUT (10-24)	Zinc Alloy
2	HAND WHEEL*	Nylon
3	STEM	316 stainless
4	WASHER	Nylon
5	O-RING	Nylon
6	PACKING NUT	Brass
7	MOUNTING NUT	FCB
8	HOUSING	Brass
9	BODY	Brass

* Optional micrometer handle - Aluminum

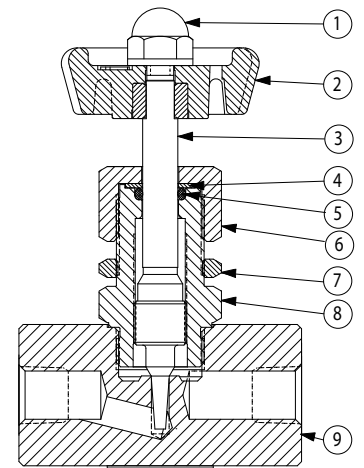

2331F[JB
Brass

Dimensions

FLOW PATTERN	A & B CONNECTIONS	PANEL MOUNTING DIMENSIONS									
			D	D'	E	F	F'	H	H'	PANEL THICKNESS	HOLE SIZE
GLOBE	¼" NPT FEMALE	inch	3.59	3.88	2	1.41	1	0.5	0.75	0.13	0.64
		mm	91	98	51	36	25	12.7	19	3	16
	⅛" NPT FEMALE	inch	3.59	3.88	2	1.41	1	0.5	0.75	0.13	0.64
		mm	91	98	51	36	25	12.7	19	3	16
¼" GYROLOK®	inch	3.59	3.88	2.63	1.41	1	0.5	0.75	0.13	0.64	
	mm	91	98	67	36	25	12.7	19	3	16	
ANGLE	¼" NPT FEMALE	inch	3.75	4.06	1.44	1.41	1	0.56	0.81	0.13	0.64
		mm	95	103	37	36	25	14	21	3	16
	⅛" NPT FEMALE	inch	3.75	4.06	1.44	1.41	1	0.56	0.81	0.13	0.64
		mm	95	103	37	36	25	14	21	3	16

Dimensions for reference only, subject to change.

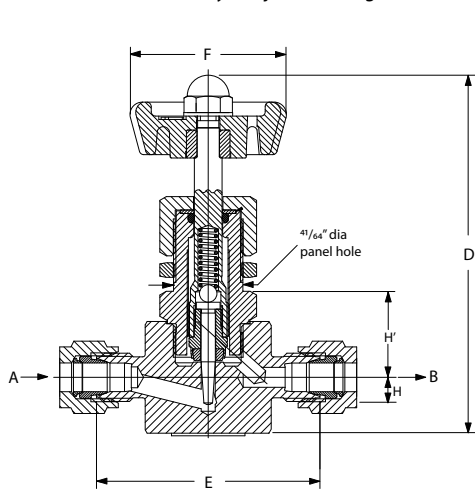

2335G[JY / 2315G[JY
316 stainless steel

HOKE Metering Valves

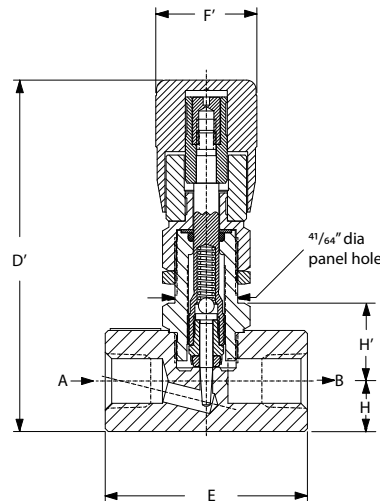

2335F4Y / 2315F4Y
316 stainless steel
(with optional micrometer handle)

HOKE Metering Valves

2300 Series

Curves

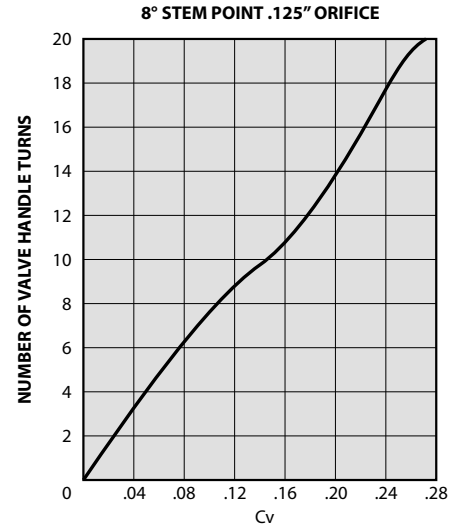
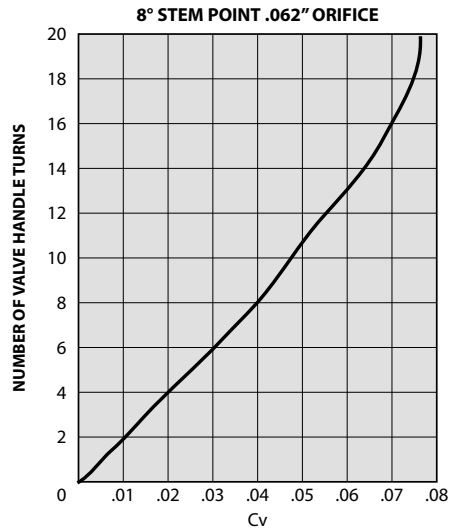
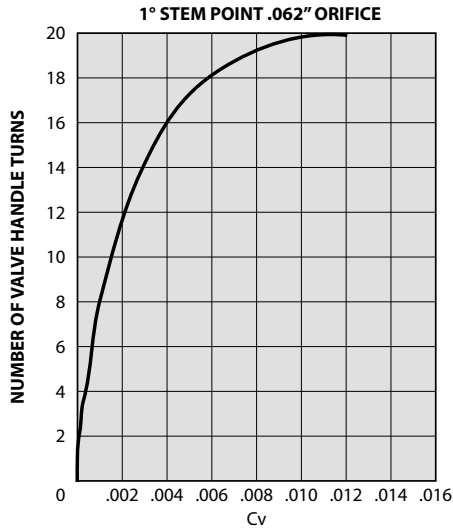

How to Order

FLOW PATTERN	CONNECTIONS	316 STAINLESS STEEL VALVES			BRASS VALVES	
		TEFLON® PACKING			BUNA-N O-RING PACKING	
		1° STEM SPRING LOADED	8° STEM SPRING LOADED	8° STEM SPRING LOADED	SOLID 8° STEM	SOLID 8° STEM
		.062" ORIFICE	.062" ORIFICE	.125" ORIFICE	.062" ORIFICE	.125" ORIFICE
GLOBE	1/8" NPT FEMALE	2355F2Y	2315F2Y	2335F2Y	2311F2B	2331F2B
	1/4" NPT FEMALE	2355F4Y	2315F4Y	2335F4Y	2311F4B	2331F4B
	1/4" GYROLOK®	2355G4Y	2315G4Y	2335G4Y	—	2331G4B
ANGLE	1/8" NPT FEMALE	—	—	—	2321F2B	2341F2B
	1/4" NPT FEMALE	—	—	—	2321F4B	2341F4B

Ordering Options

Spare Parts

Spare parts and repair kits are available for all needle valves. Please contact your distributor for specific information.

Cleaning and Testing

When ordering, please specify if oxygen cleaning or helium leak testing is required.

Additional Sizes

Additional sizes and options are available on special request. Please consult your local HOKE distributor.

Liquid Flow capacity of Hoke Metering Valves

To determine the Cv or flow of a **liquid** @ 60° F (16° C):

$$Cv = \frac{GPM}{\sqrt{\frac{\Delta p}{S.G.}}} \quad \text{or} \quad GPM = Cv \sqrt{\frac{\Delta p}{S.G.}}$$

where: $\Delta p = p_1 - p_2$
 $p_1 =$ inlet pressure in psia
 $p_2 =$ outlet pressure in psia
 GPM = flow in gallons per minute
 S.G. = specific gravity of liquid where water = 1.0 @ 60° F (16° C)

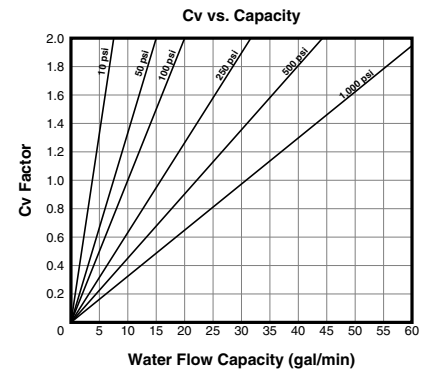

Gas Flow capacity of Hoke Metering Valves

To determine the Cv or flow of a **gas** @ 70° F (21° C):

$$Cv = \frac{SCFH}{1360 \sqrt{\frac{(\Delta p) (p_1)}{(460 + T) (S.G.)}}} \quad \text{or} \quad SCFH = 1360 Cv \sqrt{\frac{(\Delta p) (p_1)}{(460 + T) (S.G.)}}$$

where: $\Delta p = p_1 - p_2$
 $p_1 =$ inlet pressure in psia
 $p_2 =$ outlet pressure in psia
 SCFH = flow in standard cubic feet per hour
 S.G. = specific gravity of gas where air = 1.0 @ 70° F (21° C) and 14.7 psia
 T = temperature in ° F

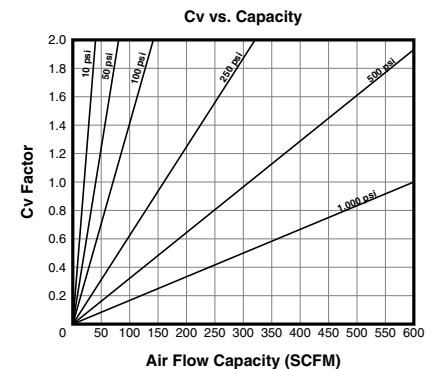

Specifying metering valves for critical analytical instrumentation and applications which demand precise stem positioning requires a complete knowledge of your process conditions.

Before you start, it is important that your flow requirements be defined in terms of Cv or flow coefficient.

Cv is the valve flow coefficient expressing the rate of flow in gallons per minute of 60° F water with a pressure drop of 1 PSI across the valve. By correctly using the formula for liquids or gases, you will obtain an accurate Cv, necessary for your valve selection.

Cv should be calculated for expected variations in pressure and required flow range. The Cv range for Hoke metering valves is approximately 10 to 1. This is illustrated in the Cv vs handle turns flow curves shown with each valve series. Note that the more handle turns required to achieve a specified change in flow, the greater the valve's accuracy.

The Cv range providing best control should fall within the straight portion of the curve with the nominal value centered. Using the straight portion of the curve gives approximately the same incremental flow for each turn of the valve handle.

Once Cv requirements are determined, the following steps must be evaluated before making your final valve selection.

1. Define Pressure/Temperature Requirements

Hoke metering valves are available from moderate vacuum to 5000 psig. Operating temperatures range from -65° to 450° F. There are no restrictions on pressure drop or downstream pressure for Hoke valves, however, best performance will be obtained if the downstream pressure is more than 50% of the inlet pressure.

2. Know Your Material Requirements

Corrosion resistance should be your prime consideration when selecting materials, particularly the wetted or pressure boundary parts. There are times when the environment must also be considered in addition to the fluid media.

The pressure/temperature demands of materials are normally covered by the material manufacturer's product specifications.

Hoke products are designed using materials of similar corrosion properties whenever possible. If material selection is critical, please contact your nearby Hoke distributor. He can recommend options to help solve your problem.

3. Options

Dial Indicator and micrometer handles are available for reproducing stem positioning. The Hoke Milli-Mite 1300 series is provided with a micrometer handle as standard equipment. Other handle options are available or can be made to order.

4. Final Performance

Engineering design and manufacturing standards are critical elements of the metering valve you select and will affect its actual performance.

Total control of these quality elements at Hoke assures you of valves with excellent stem positioning repeatability, low hysteresis, and extended metering range.